

SPECTRORADIOMETER CS-1000A Hardware

INSTRUCTION MANUAL

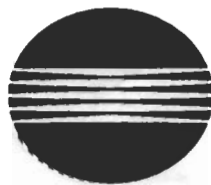

KONICA MINOLTA

Safety Symbols

The following symbols are used in this manual to prevent accidents which may occur as result of incorrect use of the instrument.



Denotes a sentence regarding safety warning or note.
Read the sentence carefully to ensure safe and correct use.



Denotes a prohibited operation.
The operation must never be performed.



Denotes an instruction.
The instruction must be strictly adhered to.



Denotes an instruction.
Disconnect the AC adapter from the AC outlet.













Denotes a prohibited operation.
The part must never be disassembled.



Notes on this Manual

- Copying or reproduction of all or any part of the contents of this manual without KONICA MINOLTA's permission is strictly prohibited.
- The contents of this manual are subject to change without prior notice.
- Every effort has been made in the preparation of this manual to ensure the accuracy of its contents. However, should you have any questions or find any errors, please contact a Konica Minolta authorized service facility.
- KONICA MINOLTA will not accept any responsibility for consequences arising from the use of the instrument.

SAFETY PRECAUTIONS

To ensure correct use of this instrument, read the following points carefully and adhere to them. After you have read this manual, keep it in a safe place where it can be referred to anytime a question arises.

 WARNING (Failure to adhere to the following points may result in death or serious injury.)	
 Do not use the instrument in places where flammable or combustible gases (gasoline etc.) are present. Doing so may cause a fire.	 The instrument should not be operated if it is damaged, or smoke or odd smells occur. Doing so may result in a fire. In such situations, turn the power OFF immediately, disconnect the AC adapter, and contact a Konica Minolta authorized service facility.
 Always use the AC adapter supplied as a standard accessory with the instrument, and connect it to an AC outlet (120 V , 60Hz or 230 V , 50 Hz). Damage to the AC adapter may cause a fire or electric shock.	 Do not disassemble or modify the instrument. Doing so may cause a fire or electric shock.
 If the instrument will not be used for a long time, disconnect the AC adapter from the AC outlet. Accumulated dirt or water on the prongs of the adapter may cause a fire and should be removed.	 Take special care not to allow liquid or metal objects to enter the instrument. Doing so may cause a fire or electric shock. Should liquid or metal objects enter the instrument, turn the power OFF immediately, disconnect the AC adapter, and contact a Konica Minolta authorized service facility.
 Do not insert or disconnect the AC adapter with wet hands.	 Never aim the instrument directly at the sun and look through the viewfinder. Doing so can damage your eyes.
 Do not disassemble or modify the AC adapter. Doing so may cause a fire or electric shock.	 Never aim the instrument directly at the sun and look through the viewfinder. Doing so can damage your eyes.

 CAUTION (Failure to adhere to the following points may result in injury or damage to the instrument or other property.)	
 Do not walk while looking through the view finder. Doing so may cause you to trip or bump something.	 Do not place the instrument on an unstable or sloping surface. Doing so may result in its dropping or overturning, causing injury. Take a care not to drop the instrument when carrying it.

CONTENTS

INTRODUCTION	4
HANDLING PRECAUTIONS	4
Notes on Use	4
Notes on Storage	4
Notes on Transport	5
Maintenance and Inspection	5
NAME OF PARTS AND FUNCTIONS OF CONTROLS	6
SYSTEM CONFIGURATION DIAGRAM	8
LCD DISPLAY	8
<i>Preparation</i>	9
ATTACHING AN OBJECTIVE LENS	10
CONNECTING THE AC ADAPTER	11
TURNING POWER ON AND OFF	12
EYEPIECE ADJUSTMENT	13
CHECKING THE VERSION OF THE MAIN BODY	14
<i>Setting</i>	15
SETTING THE MENU	16
Selecting Measurement Mode (MEAS. MODE)	16
Selecting Display Mode	19
Setting Absolute Value (ABS.) or Color Difference (DIFF) Display Mode	21
Setting the Observer	22
Setting the Baud Rate	23
Setting the Measuring Speed (SPEED)	24
<i>Measurement</i>	25
MEASURING A CONTINUOUS LIGHT	26
MEASURING A FLICKER LIGHT	28
Saving the Measured Data	30
Saving the Target Data and Setting It	32
Deleting Measured Data	37
Deleting Target Data	39
Displaying Color Difference/Relative Luminance	41

Communication	45
CONNECTING THE CS-1000A TO A PERSONAL COMPUTER.....	46
<Setting the Communication Parameters>	46
COMMAND LIST	48
DELIMITER CODE	48
INPUT/OUTPUT FORMAT	48
ERROR CHECK CODES	49
INPUT/OUTPUT FORMAT OF EACH COMMAND	50
<RMT>	50
<SPS>	51
<SPR>	51
<MES>	52
<MMS>	54
<STR>	55
<BDR>	56
<MDR>	63
<TDR>	69
<MDD>	75
<TDD>	75
<TDS>	76
Explanation	77
MEASUREMENT PRINCIPLE	78
DARK MEASUREMENT	78
MEASURING COLOR OF THE OBJECT	79
ERROR MESSAGES	80
TROUBLESHOOTING	81
DIMENSION DIAGRAM	82
SPECIFICATIONS	83

INTRODUCTION

CS-1000A is an integrated type spectroradiometer, designed for high-speed and high-accuracy measurement of light source color of display devices such as CRT and LCD, and lighting devices such as lamps. In this manual, the word "CS-1000A" is used to express the instrument.

Notes on Packing Materials

Keep the packing materials (corrugated boards, cushions, polyvinyl bags etc.) in a safe place. This CS-1000A is an accurate measuring instrument. Thus to minimize shock and vibration during transport, for instance when returning the CS-1000A to Konica Minolta for maintenance, always use these packing materials. Should the packing materials be lost or damaged, consult the nearest Konica Minolta authorized service facility.

HANDLING PRECAUTIONS

Notes on Use

- Use an AC power source which is within $\pm 10\%$ of the rated voltage.
- This CS-1000A should be used in ambient temperatures of between 5 and 35°C at a relative humidity of 80% or less. No condensation is allowed.
- Do not use or leave this CS-1000A near sources of heat such as stoves. When using this CS-1000A outside, take care not to expose it to direct sunlight. Doing so will cause the temperature of the CS-1000A to rise considerably and may result in malfunctions.
- When using this CS-1000A in a cold environment, do not allow it to be exposed to rapid temperature changes. Doing so may cause condensation, resulting in improper measurements or malfunctions, which will require repair.
- Do not use this CS-1000A in extremely dusty or humid areas.
- Do not subject this CS-1000A to strong vibration or shocks. Doing so may result in malfunctions.
- Do not pull or bend the cords forcibly. Doing so may result in wire breakage.
- When measuring an intensity of 3 cd/m² or less after the CS-1000A has not been used for a long period of time (30 minutes or more), the value obtained from the first measurement may differ from those obtained from the 2nd and subsequent measurements. In such case, the values obtained from the 2nd and subsequent measurements must be used.

Objective Lens

- The objective lenses supplied with this CS-1000A are designed for use with this CS-1000A. Using an objective lens designed for other cameras will hinder proper measurements. Always use one of the objective lenses supplied with this CS-1000A.
- Check that the lens no. of each objective lens supplied with this CS-1000A matches the body no. of this CS-1000A. Using an objective lens supplied with another CS-1000A unit will hinder proper measurements. Always use one of the objective lenses supplied with this CS-1000A.
- If purchase of a new objective lens is required due to damage of the current one(s), re-calibration is required. Thus, return this CS-1000A to the nearest Minolta-authorized service facility.
- Before performing measurements, make sure that the surface of the objective lenses are clean. If dust, dirt or finger prints are present, correct measurements may be hindered.
- Do not touch the surface of the objective lenses and dust-proof glass with fingers. If dirt or dust is present, wipe it off with a soft cloth. If the surface is extremely dirty, wipe it with a soft cloth moistened with lens-cleaning fluid may be used. Never use acetone or organic solvent.
- Rapid changes in the ambient temperature high humid environment will cause the objective lenses to cloud over, hindering correct measurements.

Notes on Storage

- This CS-1000A should be stored in areas with temperatures of between 0 and 45°C at a relative humidity of 80% or less. No condensation is allowed. Do not store this CS-1000A in areas subject to high temperature or high humidity. We recommend storing this CS-1000A at a relatively constant temperature with a desiccant (silica gel etc.).
- Make sure that no condensation develops during storage. During transport to the storage area, take care not to allow rapid temperature changes which may cause condensation.
- Use the packing materials (supplied with this CS-1000A) or hard case and store the CS-1000A in a safe area.

Objective Lens

- When storing this CS-1000A with an objective lens installed, make sure that a protective cap is attached to the objective lens. Also attach a protective cap to the objective lens when the lens is removed from the CS-1000A and left to stand. In addition, make sure that a protective cap is also attached to the dust-proof glass.

Notes on Transport

- To minimize shock and vibration during transport of this CS-1000A, use the packing materials supplied when this CS-1000A was purchased.
- When returning this CS-1000A to Minolta for service maintenance, make sure that the objective lenses, AC adapter and RS-232C cables are packed with the CS-1000A.

Maintenance and Inspection

- To maintain the designed measurement accuracy of the CS-1000A, it is recommended that inspection be carried out approximately once a year.

NAME OF PARTS AND FUNCTIONS OF CONTROLS

<NAME OF PARTS>

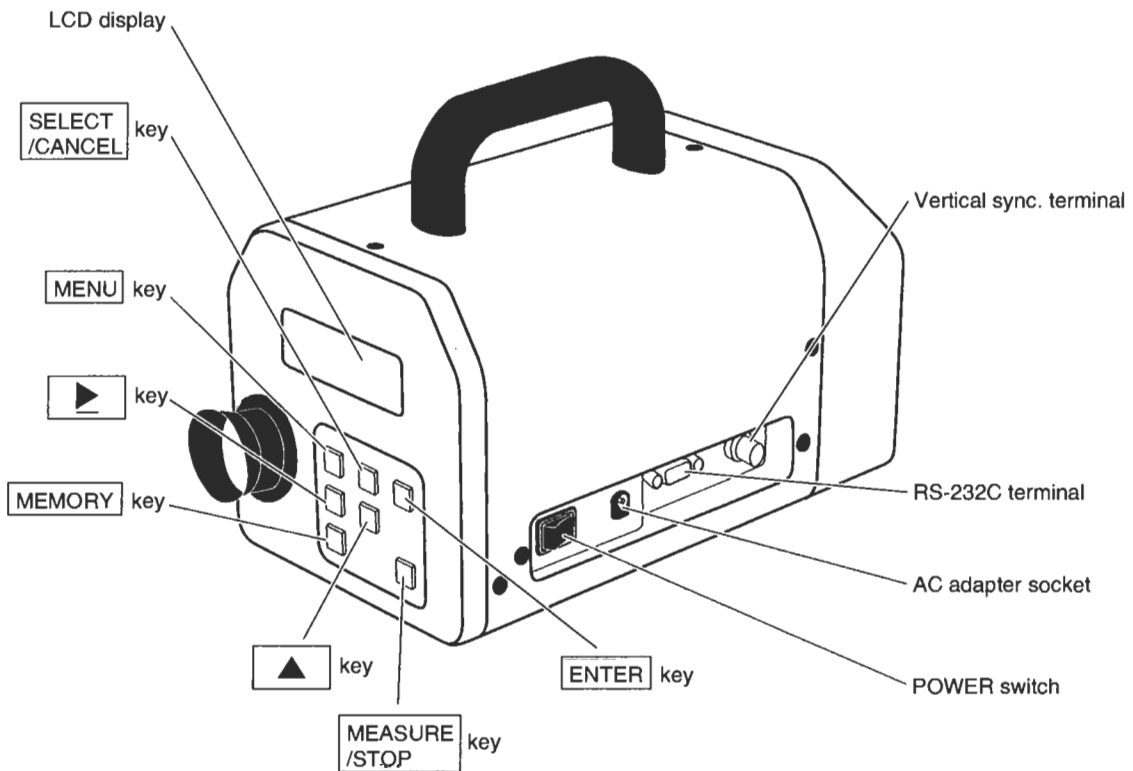
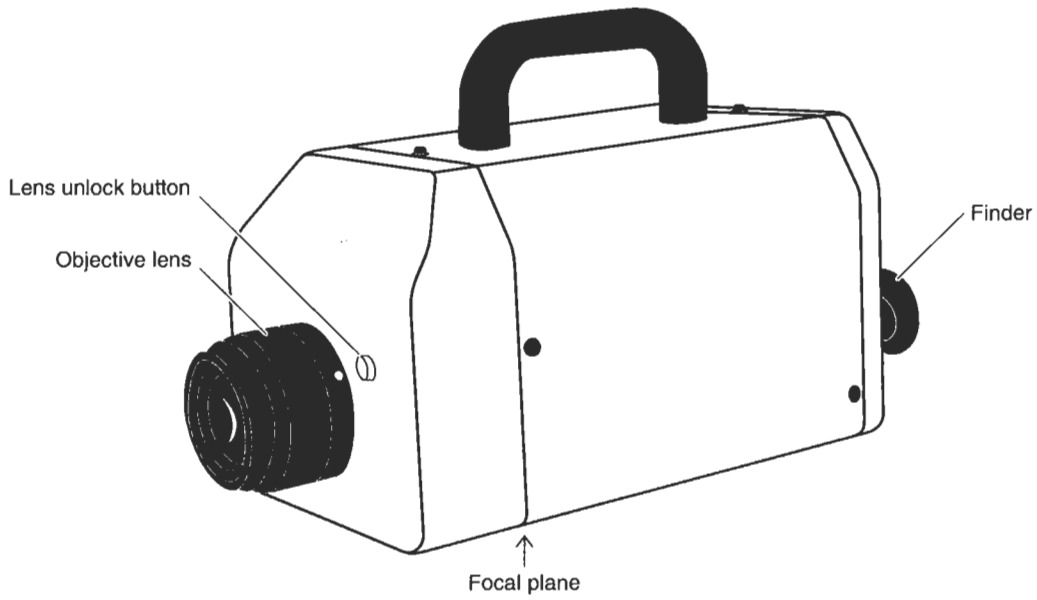

FUNCTIONS OF CONTROLS

- POWER** switch Used to turn the power On/Off.
- AC adapter socket** Connect to the AC adapter (supplied with this CS-1000A).
- RS-232C terminal** Used when connecting this CS-1000A with a personal computer via the RS-232C interface.
- Vertical sync. input terminal** ... Connect to the vertical synch. output terminal of the display device.
- Lens unlock button** Used to unlock the objective lens.
- MEASURE/STOP** key Used to start measurement. Pressing this key while measurement is in progress will stop measurement. Pressing this key during remote control mode (i.e. the CS-1000A is controlled by a personal computer) will cancel remote control mode and switch to local mode.
- MENU** key Used to switch the screen between measurement and setting screens.
- SELECT/CANCEL** key Pressing this key during mode selection in the setting screen will move the "▶" mark, enabling the user to select the desired mode. If this key is pressed after a numeric value is entered, the value will be canceled. Pressing this key at the end of measurement will enable the user to check the integration time.
- ▶ key Used to move the cursor to set a numeric value.
- ▲ key Used to change a numeric value.
- MEMORY** key Used to switch the screen between measurement and memory screens.
- ENTER** key Used to save data in the memory after the data has been selected. Pressing this key while a numeric value is being entered or saved in the memory will set the value.

SYSTEM CONFIGURATION DIAGRAM

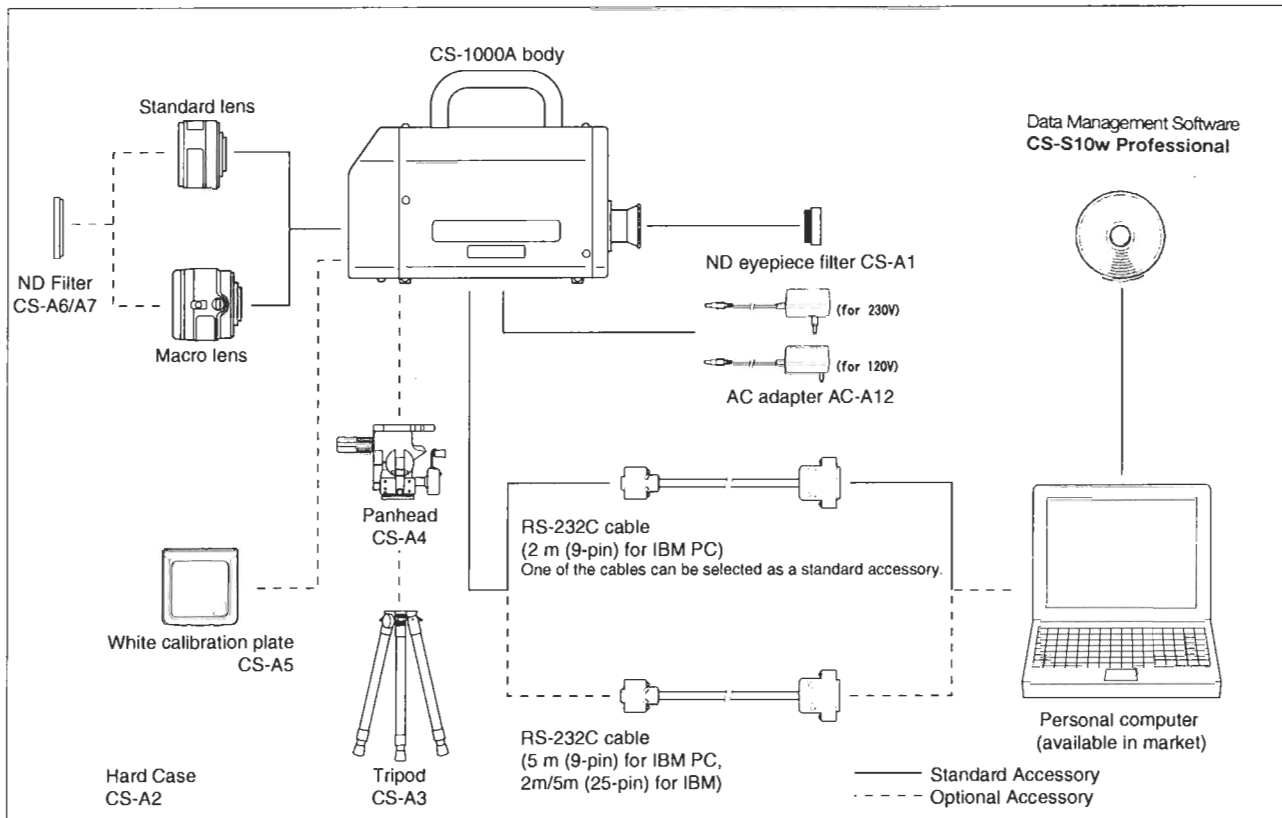

LCD DISPLAY

The following three screens are displayed on the LCD provided on the CS-1000A.

Measurement screen

Displayed at the end of measurement.

AUTO	
Lv =	103.4cd/m ²
x =	0.1546
y =	0.2475

Menu screen

Used to set the menu. This screen is displayed when the **MENU** key is pressed.

*** MENU ***	
DISP.MODE:	Lvxy
ABS./DIFF:	ABS.

Memory screen

Used to save measured data and target data. This screen is displayed when the **MEMORY** key is pressed.

SAVE TARGET :	T1
Lv =	103.4cd/m ²
x =	0.1546
y =	0.2475

Preparation

ATTACHING AN OBJECTIVE LENS

After the power is turned on, the CS-1000A detects the type of currently attached objective lens just before it starts measurement. If no objective lens is attached to the CS-1000A, measurement cannot be started.

Two types of objective lens are available with this CS-1000A: standard objective lens (40 cm to ∞) and macro objective lens (20 cm to ∞).

- Do not touch the surface of the objective lenses and dust-proof glass with fingers. If dirt or dust is present, wipe it off with a soft cloth. If the surface is extremely dirty, wipe it with a small amount of alcohol (high-grade alcohol). Never use acetone or organic solvent.

Attaching an objective lens

1. Align the red mark provided on the objective lens with that provided on this CS-1000A.
2. Turn the objective lens counter-clockwise until a clicking sound is heard.

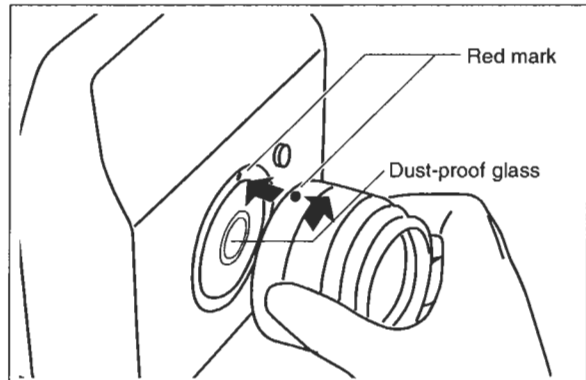

Removing an objective lens

- While holding down the lens unlock button, turn the objective lens clockwise to remove it from the CS-1000A.

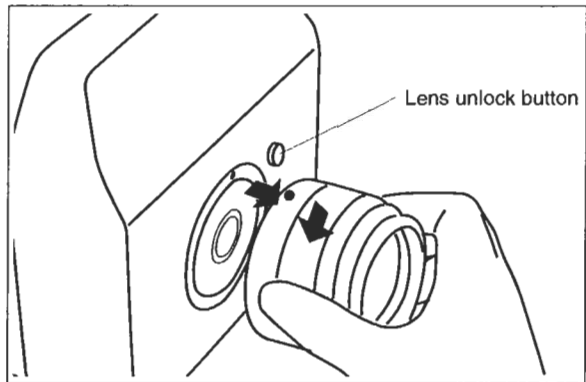

CONNECTING THE AC ADAPTER

Connect the AC adapter to this CS-1000A and an AC outlet as described below.

- Use the AC adapter AC-A12 supplied with this CS-1000A.
- Before disconnecting the AC adapter from an AC outlet, always set the POWER switch to OFF ("O").

1. Check that the POWER switch is set to OFF ("O").

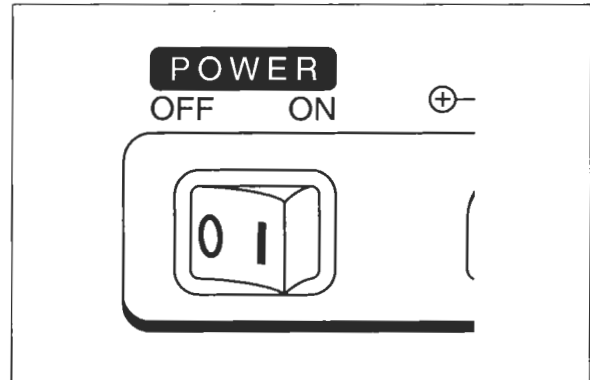

2. Plug the AC adapter into the AC adapter socket provided on this CS-1000A.

3. Plug the AC adapter into an AC outlet

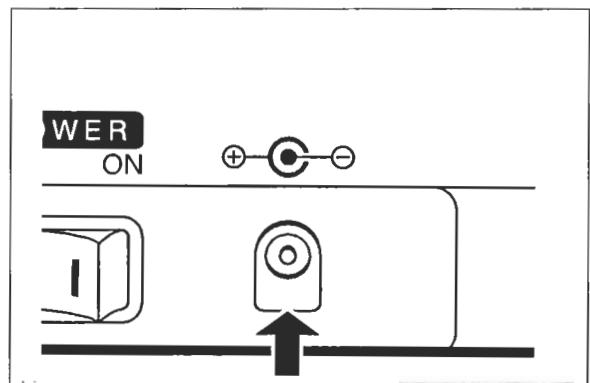

TURNING POWER ON AND OFF

It takes at least 15 minutes for the CS-1000A to stabilize. Thus, make sure that the POWER switch is set to ON ("I") to warm up the CS-1000A at least 15 minutes before start of measurement.

However, to ensure accurate measurements under the following conditions, warm-up time of 30 minutes or more is recommended.

1. When the object to be measured is a low-luminance light source: 5 cd/m² or below with 2856K (standard light source A)
2. When the operating temperature and humidity are outside the normal range

- If the power is turned off even for a short time, the CS-1000A should be warmed up again for at least 15 minutes.

1. Set the POWER switch to ON ("I").

- ◆ The CS-1000A will start up.
- ◆ The LCD displays the settings which were in effect just before the POWER switch was set to OFF last time.
- ◆ The factory settings are shown below.

AUTO.
Lv =
x =
y =

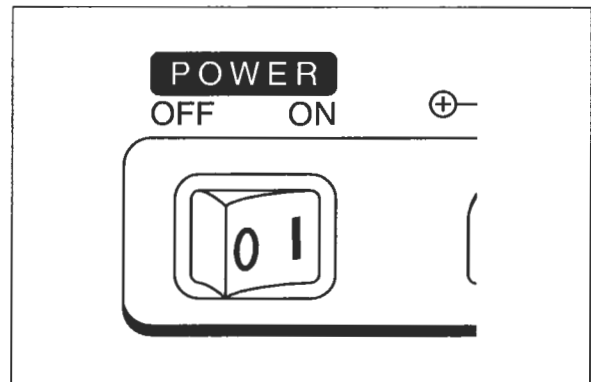

2. To turn the power off after measurement is complete, set the POWER switch to OFF ("O").

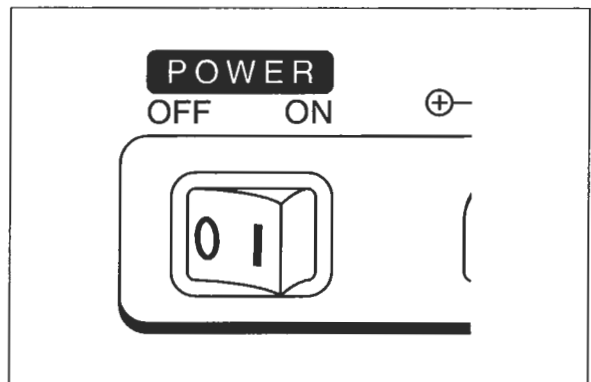

EYEPIECE ADJUSTMENT

This section describes how to adjust the eyepiece.

1. Place this CS-1000A on a stable surface or secure it to a tripod.
2. If the object is extremely bright, attach the ND eyepiece filter (supplied with this CS-1000A) to the CS-1000A.

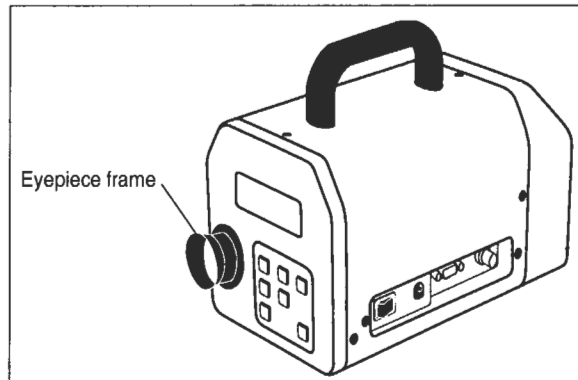

3. Turn the eyepiece frame to adjust the finder visibility.
 - Turn the eyepiece frame so that sections A and B of the aperture (i.e. black circle indicating measurement area) viewed when you look into the finder are clear.

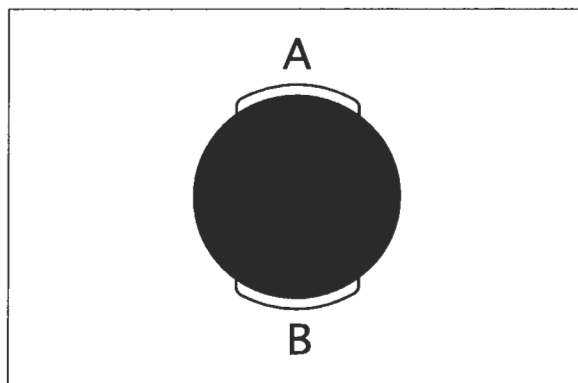

CHECKING THE VERSION OF THE MAIN BODY

If you are going to use CS-1000A with CS-S1w/CS-S2w (Ver. 2.1 or higher), the instrument version must be checked. Check the version as explained below.

Version Check Method

1. Turn the power ON while holding the **MENU** and **SELECT/CANCEL** keys together.

- ◆ The version no. will appear on the LCD.

Ver. X.XX 1501000

- Take a note of what is displayed.

1st model: 1.30xx or earlier Measuring speed is fixed.

2nd model: 1.30xx or later Measuring speed can be selected from NORMAL and FAST.

2. Press any key to exit.

- ◆ The measurement screen will reappear.

Setting

SETTING THE MENU

Selecting Measurement Mode (MEAS. MODE)

This section describes how to select measurement mode and set integration time.

Integration time: Refers to "exposure time", i.e. the period during which the sensor is measuring the light.

Measurement time: Refers to the time required for actual measurement, and is expressed as "Integration time x 2 + Chopper open/close time + Computation time". If this CS-1000A is used with a personal computer, "data transfer time" will also be taken into account.

The following four measurement modes are available.

- AUTO :** Used to measure a stationary light. Stationary light refers to stable light radiated from an electric bulb or an LED lit by constant-voltage power supply. The most suitable integration time is set automatically according to the brightness of the light source.
- If a light source whose luminance fluctuates considerably is measured in AUTO mode, an OVER/UNDER error sometimes occurs. In this case, switch the mode to MAN and set the longest integration time within the range in which no OVER/UNDER error occurs.
- INT.SYNC :** Used to measure a display device without the vertical sync. signal connected to this CS-1000A or to measure a flicker light source such as a fluorescent lamp. Enter the same frequency as the vertical sync. signal when you want to measure a display device or enter the commercial frequency (50 or 60 Hz) when you want to measure a flicker light source. The most suitable integration time is set automatically according to the entered value and brightness of the object.
The signal that is input should be the CMOS logic level (5V) signal.
- EXT.SYNC :** Used to measure a display device with the vertical sync. signal connected to this CS-1000A. The most suitable integration time is set automatically according to the frequency of the vertical sync. signal and brightness of the object.
The signal that is input should be the CMOS logic level (5V) signal.
- MAN :** This mode allows the user to specify the desired integration time. A value of between 0.04 to 60 seconds can be entered.
- If the integration time specified in MAN mode is far below the one in AUTO mode, measurement accuracy may drop. To ensure accurate measurement, it is recommended to specify integration time which is at least half the integration time set in AUTO mode.

1. Press the **MENU** key.

- ◆ The following MENU screen will appear on the LCD.

```

*** MENU ***
▶ MEAS . MODE :   AUTO
  
```

- ◆ The "▶" mark will be positioned at MEAS.MODE.

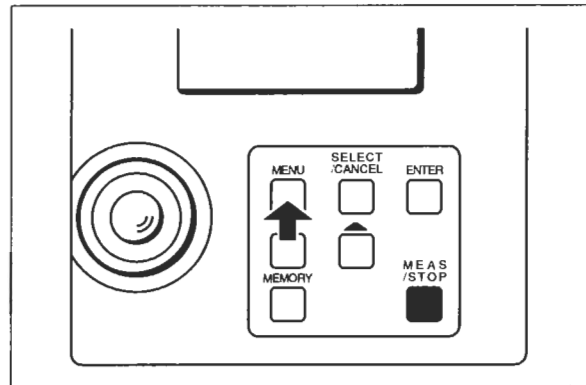

2. Press the **[▲]** key repeatedly until the desired measurement mode is displayed.

- ◆ Each time the **[▲]** key is pressed, measurement mode switches in the following order.

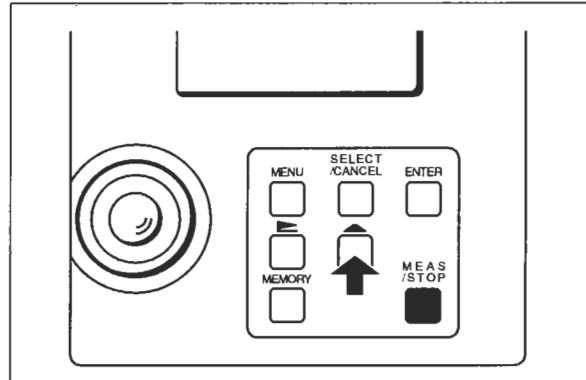
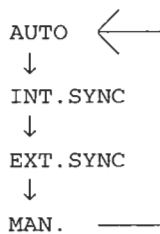

When INT.SYNC or MAN. is Selected

If INT.SYNC is selected, set the vertical sync. signal's frequency and commercial frequency. If MAN. is selected, set the integration time as described below.

3. Press the **[▶]** cursor key.

- The cursor will be positioned below the currently set value.
- ◆ Each time the **[▶]** cursor key is pressed, the cursor moves one digit.

```

*** MENU ***
▶ MEAS . MODE :  MAN .
  00 . 040 sec .
  
```

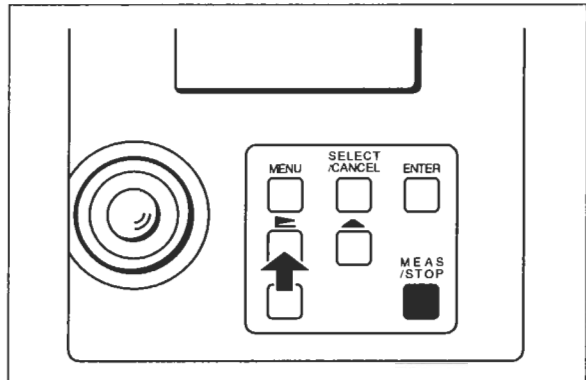

4. Press the **[▲]** key to set the desired value.

- ◆ Each time the **[▲]** key is pressed, the value increases. Holding down the **[▲]** key will cause the value to increase continuously.
- For INT.SYNC mode, a value of between 20 and 250 Hz can be set.
- For MAN. mode, a value of between 0.040 and 60.000 can be set.

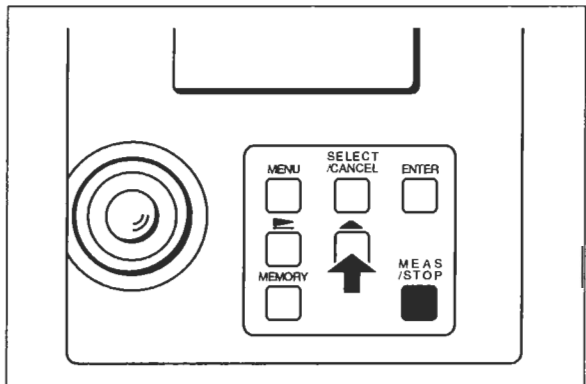

5. Press the **ENTER** key.

- ◆ The cursor below the value will disappear, indicating that the entered value has been set.
- "DATA SET ERROR" message will appear if the value is outside the above range.

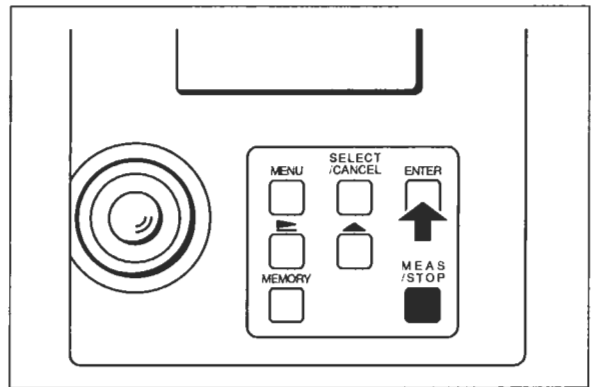

6. Press the **MENU** key.

- ◆ Measurement mode is now set.

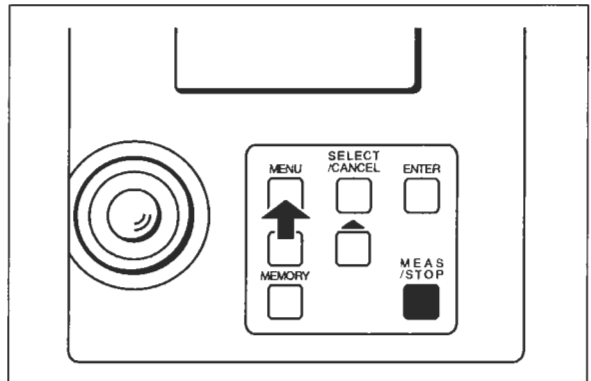

Selecting Display Mode

This section describes how to select colorimetric data type (Lvxy, Lvu'v', LvTΔuv and Le).

- ① Lv : Indicates luminance.
- ② Le : Indicates radiance.
- ③ T : Indicates correlated color temperature.
- ④ Δuv : Indicates the color difference from the blackbody locus.
 - The chromaticity range for which the relative color temperature can be applied is not specified. In general, the correlated color temperature is used within $\pm 0.02 |\Delta uv|$.
(Display range for TΔuv: $2300K \leq T \leq 20000K$ or $|\Delta uv| < 0.1$)

1. Press the **MENU** key.

- ◆ The MENU screen will appear on the LCD.

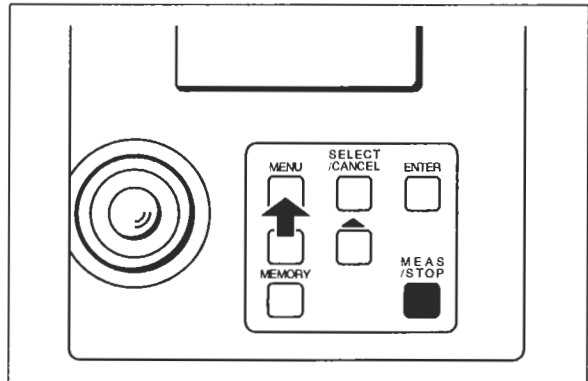
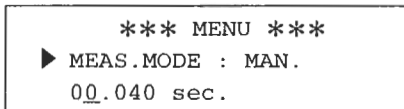

2. Press the **SELECT/CANCEL** key.

- ◆ The "▶" mark will be positioned at DISP.MODE.

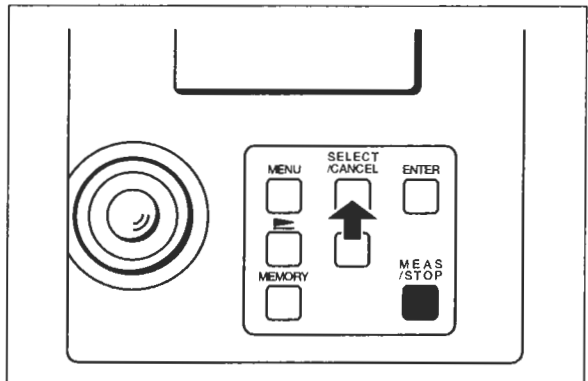
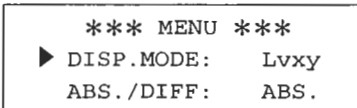

3. Keep pressing the **[▲]** key until the desired display mode is displayed.

- ◆ Each time the **[▲]** key is pressed, display mode switches in the following order.

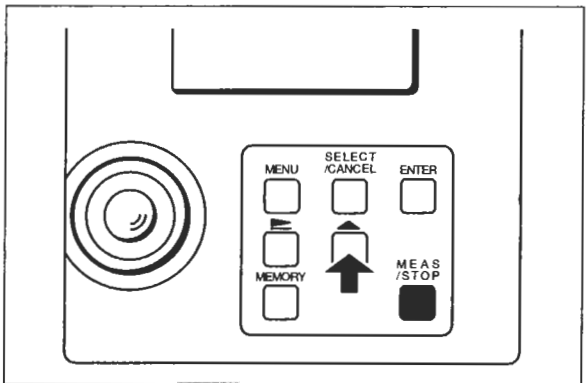
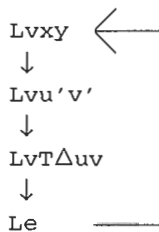

4. Press the **MENU** key.

◆ Display mode is now set.

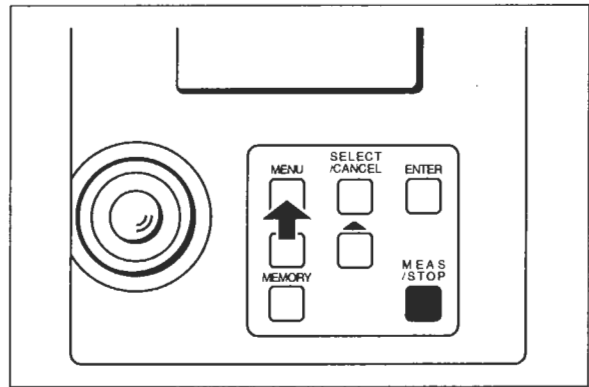

Setting Absolute Value (ABS.) or Color Difference (DIFF) Display Mode

This section describes how to select whether chromaticity in absolute value (ABS.) or in color difference (DIFF) is displayed. If selection is made so that chromaticity is displayed in color difference, luminance will be displayed in relative values (%).

- Color difference can be displayed only when Lv_{xy} or $Lv_u'v'$ display mode is selected.
- When $LvT\Delta uv$ or L_e is selected at display mode, ABS. Is displayed regardless of settings.
(Display range for $Lv\%$: Relative luminance is 999900% or less for color difference)

1. In the initial screen, press the **MENU** key.

- ◆ The MENU screen will appear on the LCD.

```

*** MENU ***
▶ MEAS.MODE : MAN.
  00.040 sec.
    
```

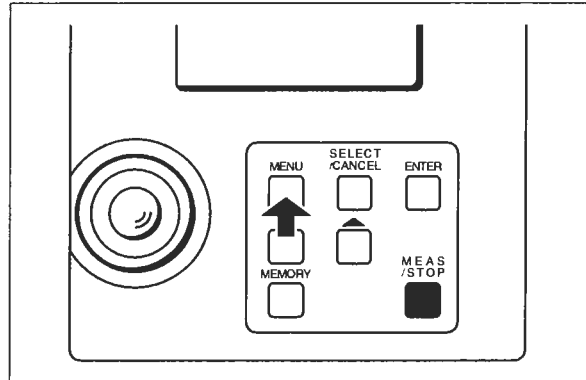

2. Press the **SELECT/CANCEL** key twice.

- ◆ The "▶" mark will be positioned at ABS./DIFF.

```

*** MENU ***
DISP.MODE:  Lvxy
▶ ABS./DIFF:  ABS.
    
```

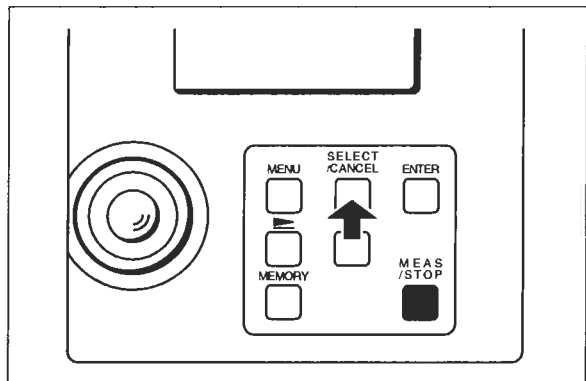

3. Press the [▲] key to select ABS. to display the chromaticity in absolute value or DIFF to display it in color difference.

- ◆ Each time the [▲] key is pressed, ABS or DIFF is selected alternately.

```

ABS.  ←
↓
DIFF  —
    
```

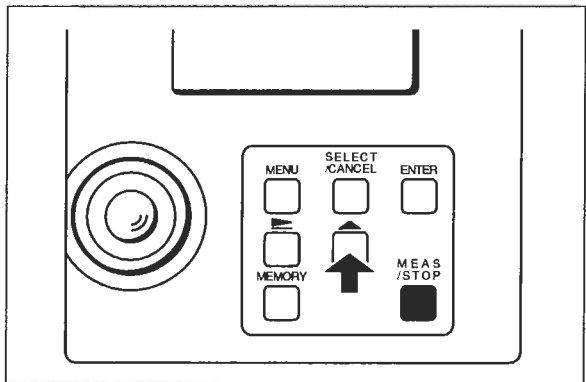

4. Press the **MENU** key.

- ◆ ABS. or DIFF display mode is now set.

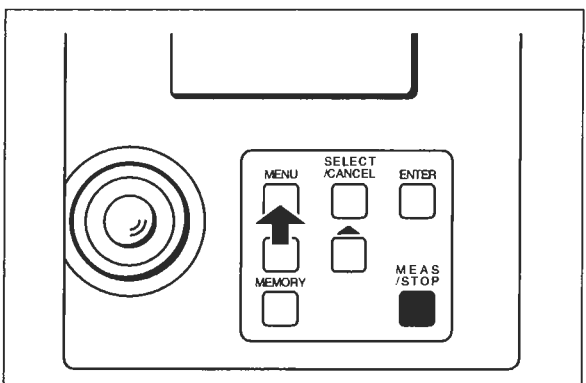

Setting the Observer

This section describes how to select the observer (2 degrees or 10 degrees) for the color matching function to be used for calculation of chromaticity.

1. Press the **MENU** key.

◆ The following MENU screen will appear on the LCD.

```
*** MENU ***
▶ MEAS.MODE : MAN.
  00.040 sec.
```

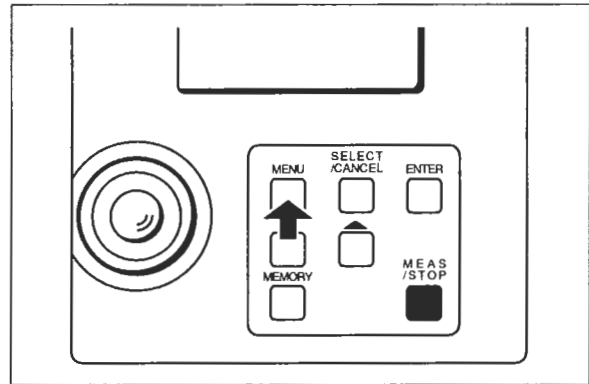

2. Press the **SELECT/CANCEL** key three times.

◆ The "▶" mark will be positioned at **OBSERVER**.

```
*** MENU ***
▶ OBSERVER   :    2°
  BAUD RATE  :   19200
```

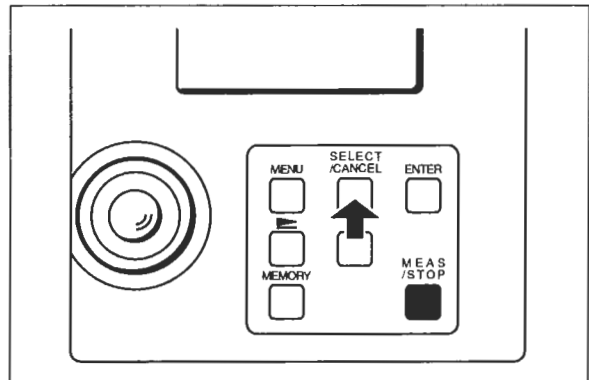

3. Press the **[▲]** key to select 2° or 10°.

◆ Each time the **[▲]** key is pressed, 2° or 10° is selected alternately.

2° ←
↓
10° ←

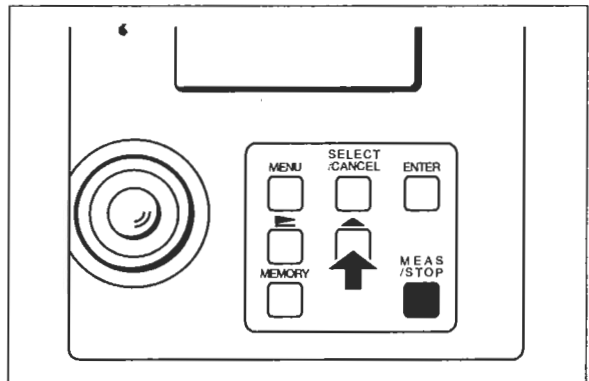

4. Press the **MENU** key.

◆ Observer is now set.

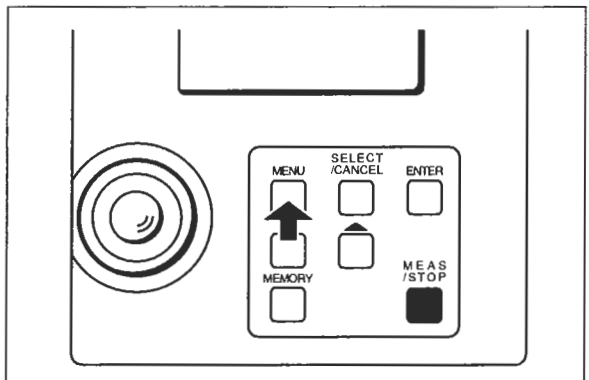

Setting the Baud Rate

This section describes how to set the baud rate for communications between this CS-1000A and a personal computer.

1. In the initial screen, press the **MENU** key.

◆ The following MENU screen will appear on the LCD.

```

*** MENU ***
▶ MEAS.MODE : MAN.
  00.040 sec.
    
```

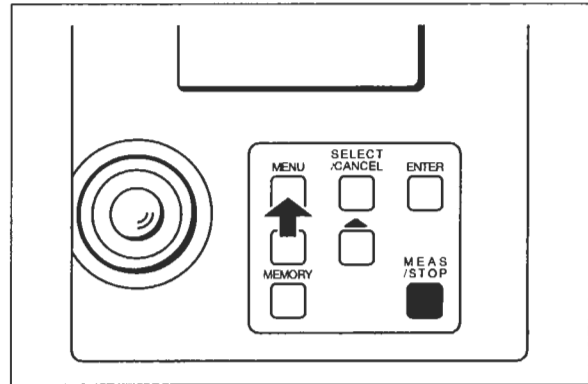

2. Press the **SELECT/CANCEL** key four times.

◆ The "▶" mark will be positioned at BAUD RATE.

```

*** MENU ***
OBSERVER      : 2°
▶ BAUD RATE   : 19200
    
```

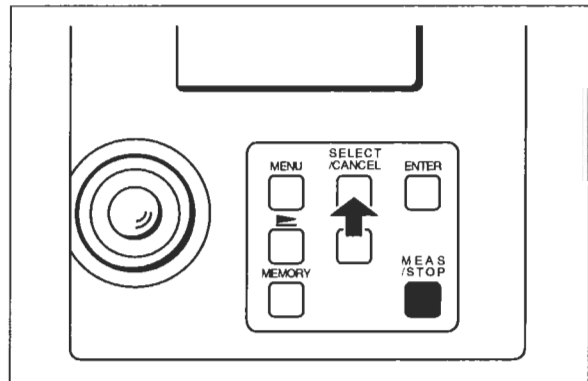

3. Keep pressing the [▲] key until the desired baud rate is selected.

◆ Each time the [▲] key is pressed, baud rate switches in the following order.

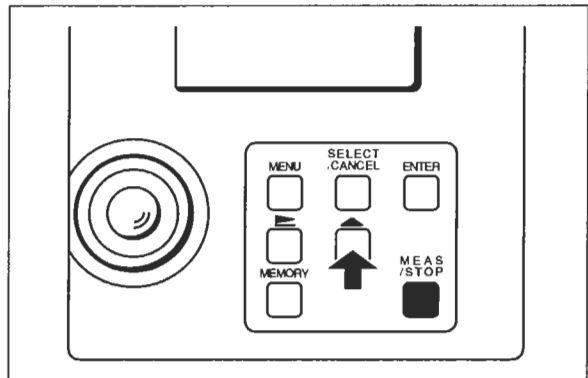
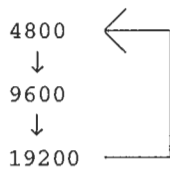

4. Press the **MENU** key.

◆ The baud rate is now set.

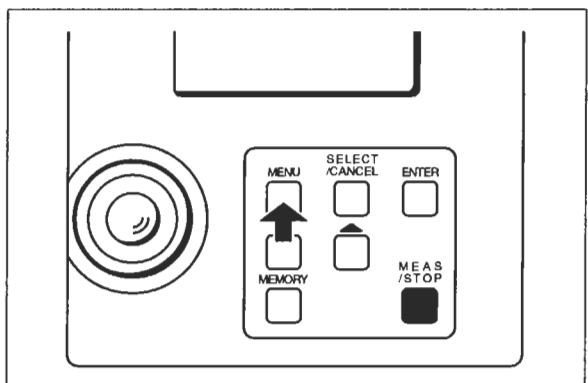

Setting the Measuring Speed (SPEED)

This section explains how to set the measuring speed of CS-1000A.

1. In the initial screen, press the **MENU** key.

- ◆ The following MENU screen will appear on the LCD.

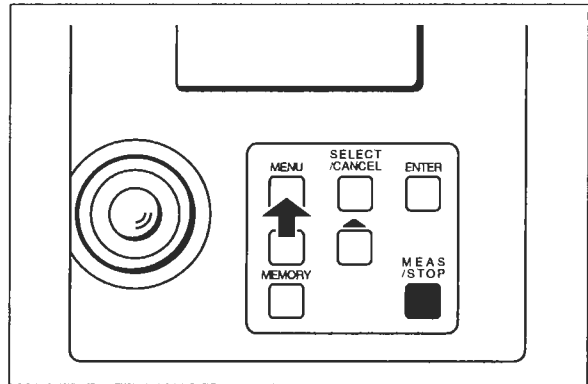

2. Press the **SELECT/CANCEL** key four times.

- ◆ The screen switches to the SPEED screen.

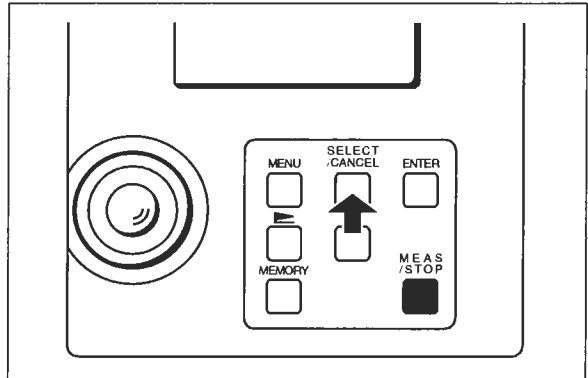
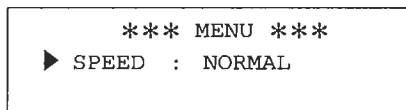

3. Press the **[▲]** key until the desired measuring speed is selected.

- ◆ Each time the **[▲]** key is pressed, measurement speed switches in the following order.

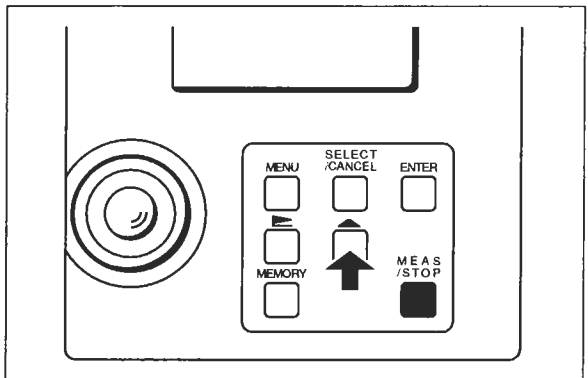
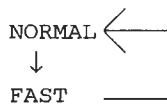

4. Press the **MENU** key.

- ◆ The selected measuring speed will be set.

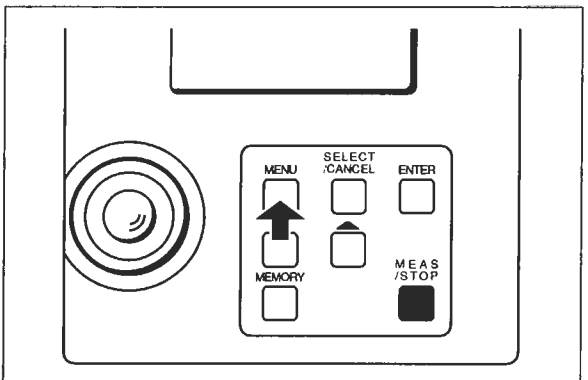

Measurement

MEASURING A CONTINUOUS LIGHT

This section describes how to measure a continuous light radiated from an electric bulb or LED lit by constant-voltage power supply.

- When performing measurements in MAN mode, if the integration time specified in MAN mode is far below the one in AUTO mode, measurement accuracy may decrease. To ensure accurate measurement, it is recommended to set the integration time which is at least half the integration time set in AUTO mode.
 - It takes at least 15 minutes for the CS-1000A to stabilize. Thus, make sure that the POWER switch is set to ON ("I") to warm up the CS-1000A at least 15 minutes before start of measurement. However, to ensure accurate measurements under the following conditions, warm-up time of 30 minutes or more is recommended.
 1. When the object to be measured is a low-luminance light source: 5 cd/m² or below with 2856K (standard light source A)
 2. When the operating temperature and humidity are outside the normal range
 - If the power is turned off even for a short time, the CS-1000A should be warmed up again for at least 15 minutes.
 - When measuring an intensity of 3 cd/m² or less after the CS-1000A has not been used for a long period of time (30 minutes or more), the value obtained from the first measurement may differ from those obtained from the 2nd and subsequent measurements. In such case, the values obtained from the 2nd and subsequent measurements must be used.
1. Set the POWER switch to ON ("I") to warm up the CS-1000A at least 15 minutes before start of measurement.
 2. Set the menu.
(See pages 16 to 24.)
 - ◆ To measure continuous light, AUTO is recommended to be selected for measurement mode.
 3. Adjust the focus ring of the objective lens.
 - ◆ Adjust the focus ring so that the peripheral area of the aperture (i.e. black circle indicating measurement area) viewed when you look into the finder is clear.

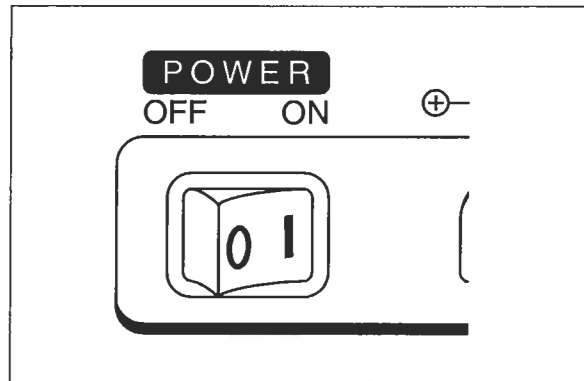

4. In the measurement screen, press the **MEASURE/STOP** key.

- ◆ Measurement will start.
Measuring time will be displayed on the LCD during measurement.

```
*** Measuring ***
MEASURING TIME
      3s
```

- To stop measurement, press the **MEASURE/STOP** key again. If measurement is stopped, the previously measured data will also be lost.
- ◆ When measurement is complete, the measurement results will be displayed as shown below.

```
AUTO
Lv = 103.4cd/m2
x = 0.1567
y = 0.2573
```

No integration time will be displayed if **AUTO**, **INT.SYNC** or **EXT.SYNC** measurement mode has been selected. To display the integration time, press the **SELECT/CANCEL** key at the end of measurement.

```
INTEGRATION TIME
      0.500s
[Push any key]
```

To return to the previous screen, press any key.
Integration time can be checked for the latest measurement only.
Integration time will be displayed in the measurement screen if **MAN** measurement mode has been selected.

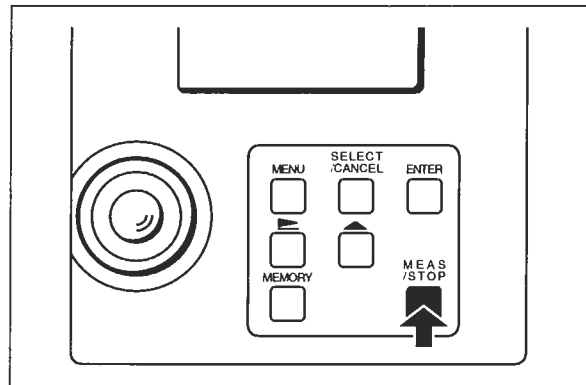

MEASURING A FLICKER LIGHT

This section describes how to measure a light source, such as a display device and fluorescent lamp, whose brightness fluctuates periodically.

If EXT.SYNC measurement mode is selected for measurement of a display device, make sure to connect the vertical sync. input terminal (BNC) of this CS-1000A to the corresponding output terminal of the display device using an appropriate BNC cable.

- It takes at least 15 minutes for the CS-1000A to stabilize. Thus, make sure that the POWER switch is set to ON ("I") to warm up the CS-1000A at least 15 minutes before start of measurement.
However, to ensure accurate measurements under the following conditions, warm-up time of 30 minutes or more is recommended.
 1. When the object to be measured is a low-luminance light source: 5 cd/m² or below with 2856K (standard light source A)
 2. When the operating temperature and humidity are outside the normal range
- If the power is turned off even for a short time, the CS-1000A should be warmed up again for at least 15 minutes.
- If EXT.SYNC measurement mode is selected, make sure that the POWER switch of this CS-1000A is set to ON ("I") before inputting the vertical sync. signal to the CS-1000A. In addition, make sure that the vertical sync. signal is not inputting from the CS-1000A before setting the POWER switch to OFF ("O").

1. Set the POWER switch to ON ("I") to warm up the CS-1000A at least 15 minutes before start of measurement.

2. Set the menu.
(See pages 16 to 24.)

- ◆ For measurement of a display device:
Select INT.SYNC or EXT.SYNC measurement mode.
- For measurement of a flicker light source such as a fluorescent lamp:
Select INT.SYNC measurement mode.

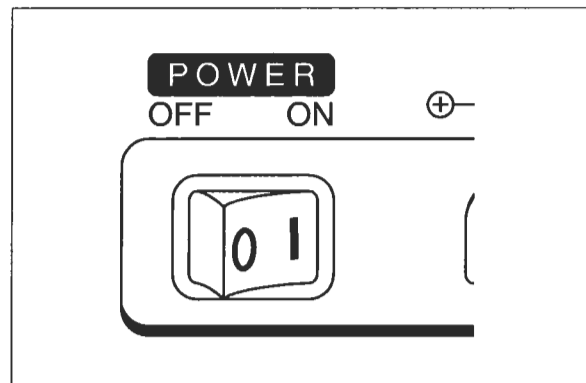

3. Press the **MEASURE/STOP** key.

- ◆ Measurement will start.
Measuring time will be displayed on the LCD during measurement.

```
*** Measuring ***  
MEASURING TIME  
3s
```

- ◆ When measurement is complete, the measurement results will be displayed as shown below.

```
INT. 60.00Hz  
Lv = 103.4cd/m2  
x = 0.1567  
y = 0.2573
```

- To stop measurement, press the **MEASURE/STOP** key again. If measurement is stopped, the previously measured data will also be lost.

No integration time will be displayed if **AUTO**, **INT.SYNC** or **EXT.SYNC** measurement mode has been selected. To display the integration time, press the **SELECT/CANCEL** key at the end of measurement.

```
INTEGRATION TIME  
0.500s  
[Push any key]
```

To return to the previous screen, press any key.
Integration time can be checked for the latest measurement only.
Integration time will be displayed in the measurement screen if **MAN** measurement mode has been selected.

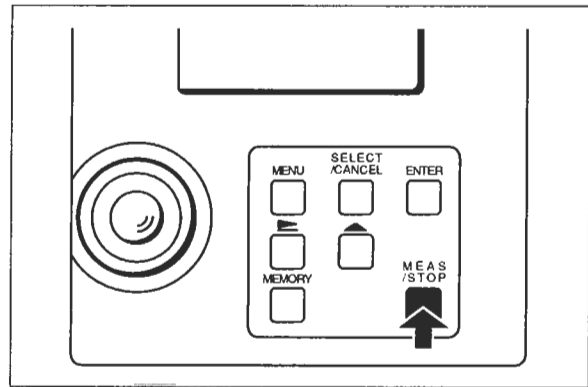

Saving the Measured Data

This section describes how to save measured data. Up to 30 measured data points can be saved.

Once measured data has been saved, it will be retained even if the AC adapter is disconnected or the power is turned off, unless it is replaced with new data.

1. Press the **MEASURE/STOP** key to start measurement.

- ◆ Measured data will be displayed as shown below when measurement is complete.

AUTO		
Lv =	103.4	cd/m ²
x =	0.1567	
y =	0.2546	

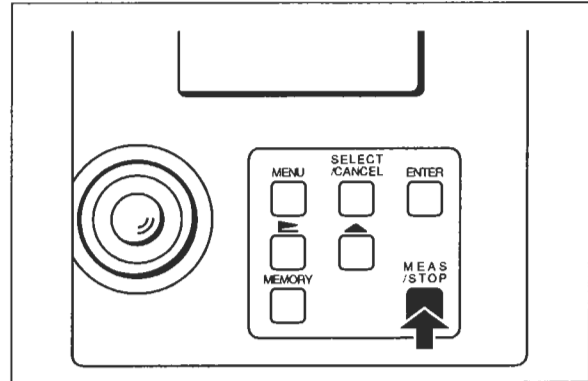

2. Press the **MEMORY** key.

- ◆ The memory screen will appear.
- ◆ "SAVE MEAS" message will appear.

▶ SAVE MEAS	:	M1
Lv =		
x =		
y =		

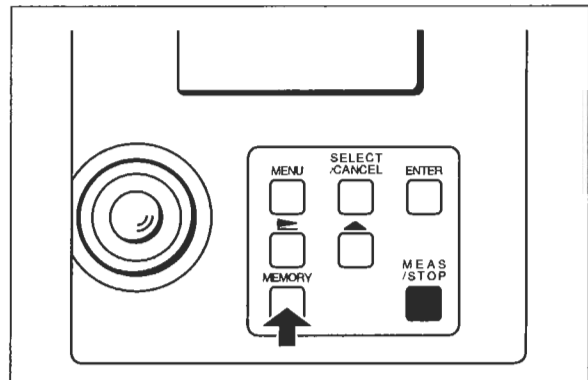

3. Keep pressing the [**▲**] key until the memory no. to which the measured data is to be saved is displayed.

- ◆ Each time the [**▲**] key is pressed, memory no. switches in the order M1, M2, M3 up to M30 and back to M1. Holding down the [**▲**] key will cause the memory no. to change continuously.
- ◆ If measured data has already been stored for the selected memory no., it will be displayed.

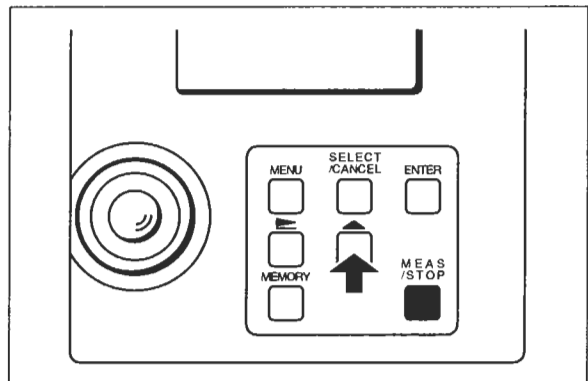

4. Press the **ENTER** key.

- ◆ "SAVE OK?" message will appear as shown below.

SAVE OK?	M1	
Yes	:	ENTER
No	:	CANCEL

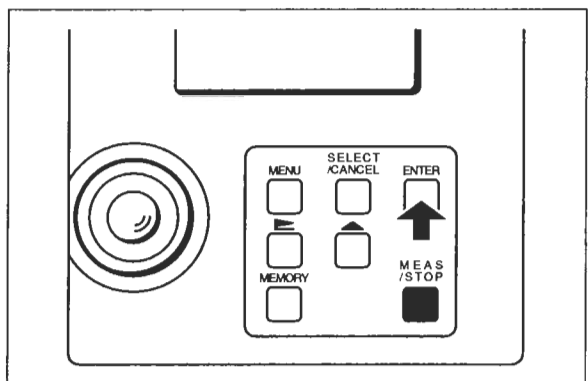

5. To save the measured data, press the **ENTER** key.

- ◆ The measured data will be saved.
- If measured data already exists in the selected memory No., it will be replaced with the new measured data.

▶ SAVE MEAS	:	M1
Lv =		103.4cd/m ²
x =		0.1572
y =		0.3467

- If you do not want to save the data, press the **SELECT/CANCEL** key.

6. Press the **MEMORY** key.

- ◆ The measurement screen will reappear.

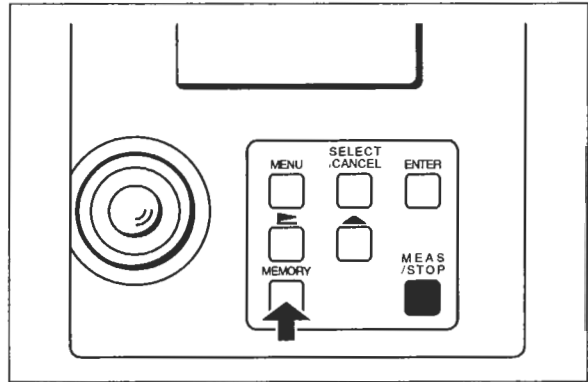
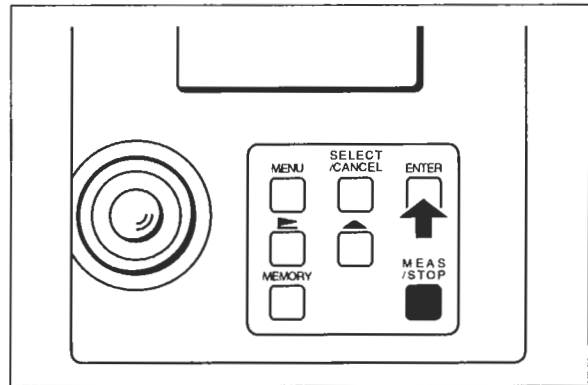

Saving the Target Data and Setting It

This section describes how to save the measured data or manually entered data as target data. The following two methods are available for saving target data.

- ① Saving the measured data as target data
- ② Entering data and saving it as target data

Up to 20 target data (TARGET) points can be saved.

Once target data has been saved, it will be retained even if the AC adapter is disconnected or the power is turned off, unless it is replaced with new data.

Saving the Measured Data as Target Data

1. Press the **MEASURE/STOP** key to start measurement.

- ◆ Measured data will be displayed as shown below when measurement is complete.

AUTO	
Lv =	103.4cd/m ²
x =	0.1560
y =	0.1579

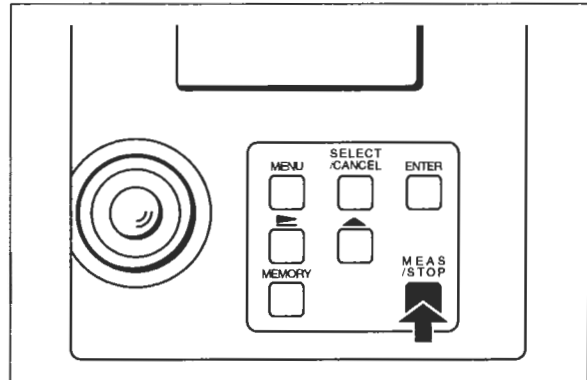

2. Press the **MEMORY** key.

- ◆ The memory screen will appear.
- ◆ "SAVE MEAS" message will appear.

▶ SEVE MEAS :	M1
Lv =	103.4cd/m ²
x =	0.1560
y =	0.1579

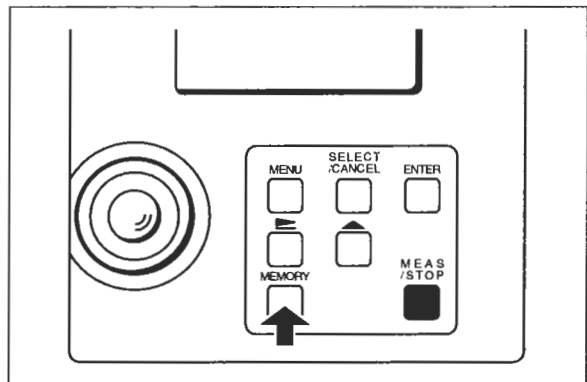

3. Press the **SELECT/CANCEL** key.

- ◆ Each time the **SELECT/CANCEL** key is pressed, the message switches in the following order.

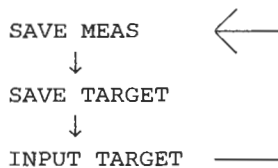

- ◆ "SAVE TARGET" message will appear.

▶ SEVE TARGET :	T1
Lv =	
x =	
y =	

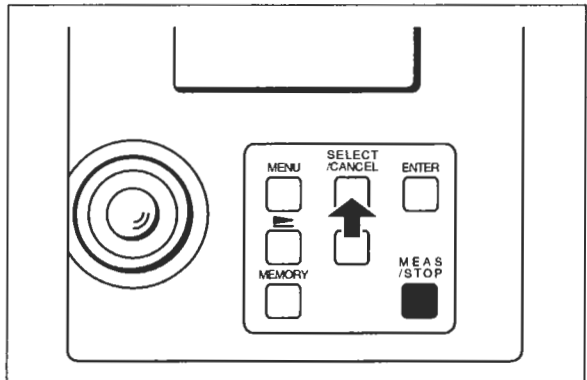

4. Keep pressing the [▲] key until the memory no. to which the target data is to be saved is displayed.

- ◆ Each time the [▲] key is pressed, memory no. switches in the order T1, T2, T3 up to T20 and back to T1. Holding down the [▲] key will cause the memory no. to change continuously.

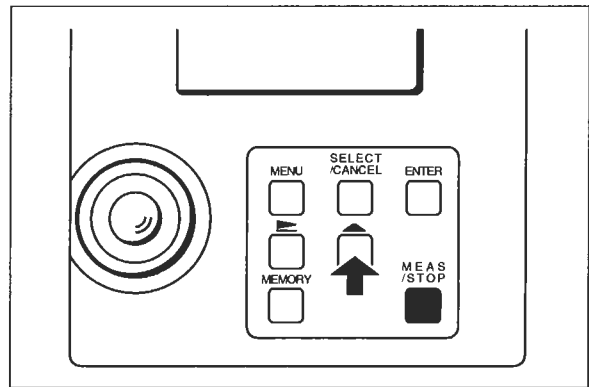

5. Press the **ENTER** key.

- ◆ "SAVE OK?" message will appear as shown below.

SAVE OK?	T1
Yes	: ENTER
No	: CANCEL

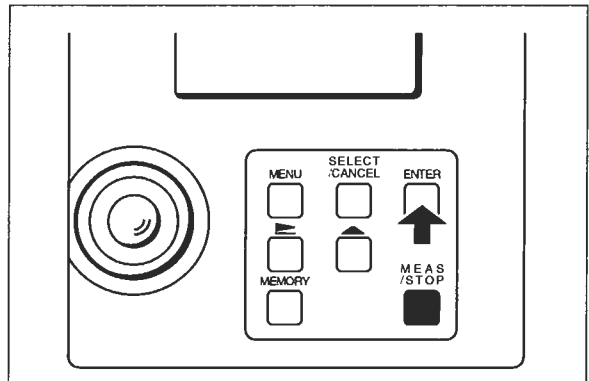

6. To save the target data, press the **ENTER** key.

- ◆ The target data will be saved.
- If target data already exists in the selected memory No., it will be replaced with the new target data.

▶ SEVE TARGET :	T1
Lv =	103.4cd/m ²
x =	0.1572
y =	0.3467

- If you do not want to save the data, press the **SELECT/CANCEL** key.

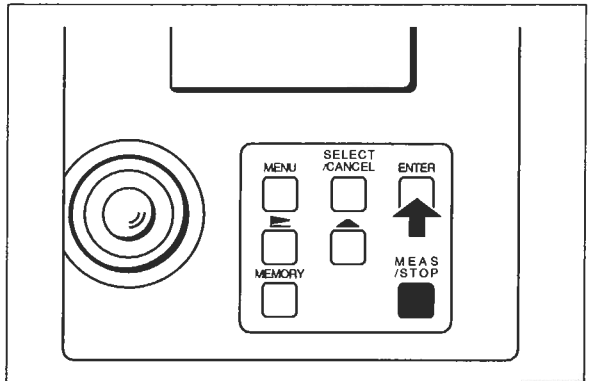

7. Press the **MEMORY** key.

- ◆ The target data will be set.

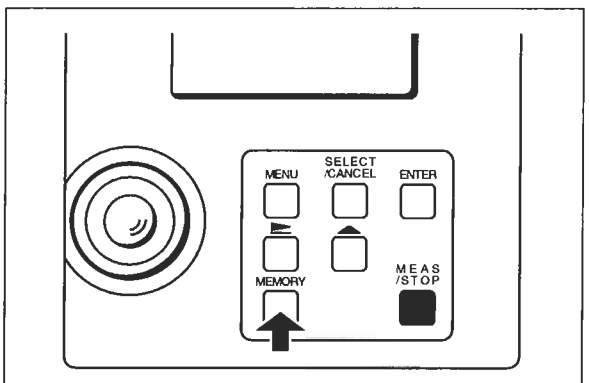

Entering Data and Saving It as Target Data

- Lvxv or Lvu'v' display mode must be selected (see pages 19 and 20).
- Target data can be entered for each observer (2° and 10°). If the both observer will be selected, the target data must be entered for both observer.

1. Select the desired observer, then press the **MEMORY** key.

- ◆ The memory screen will appear.
- ◆ "SAVE MEAS" message will appear.
- For setting the desired observer, refer to page 22.

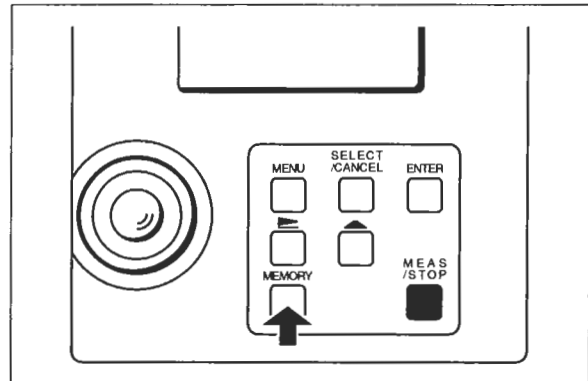

2. Press the **SELECT/CANCEL** key twice.

- ◆ "INPUT TARGET" message will appear.
- ◆ Each time the **SELECT/CANCEL** key is pressed, the message switches in the following order.

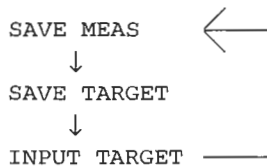

- ◆ "INPUT TARGET" message will appear.

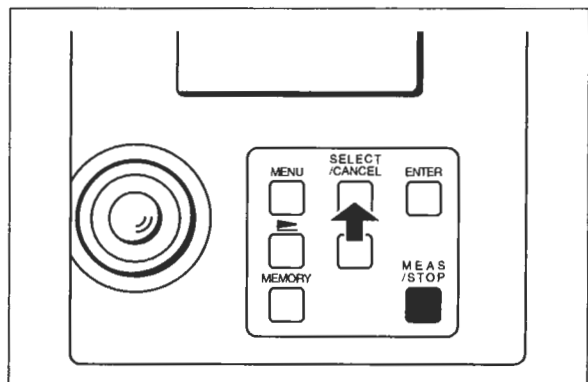

3. Keep pressing the [▲] key until the memory no. to which the manually entered data is to be saved as the target data is displayed.

- ◆ Each time the [▲] key is pressed, memory no. switches in the order T1, T2, T3 up to T20 and back to T1. Holding down the [▲] key will cause the memory no. to change continuously.

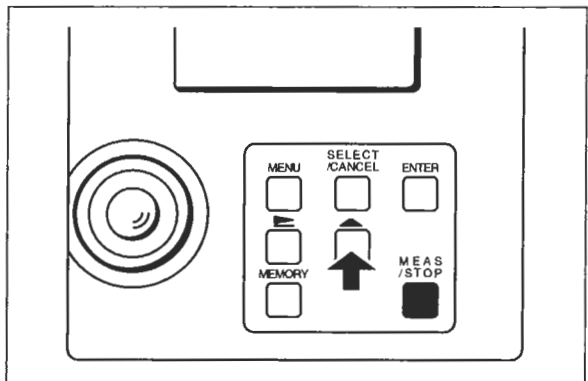

4. Press the [▶] key.

- ◆ A screen for entering the desired target data will appear.
- ◆ Each time the [▶] key is pressed, the cursor moves from a digit to another digit. Holding down the [▶] key will cause the cursor to move through digits continuously.

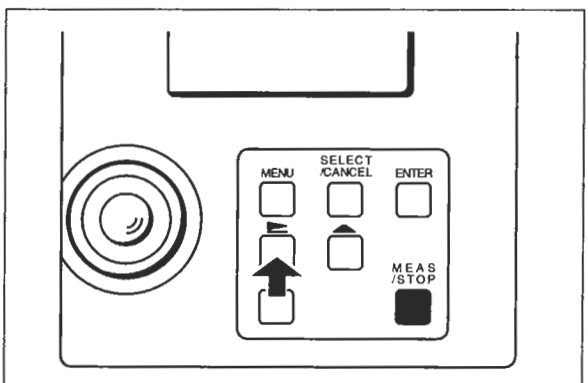

5. Keep pressing the [▲] key until the desired value is displayed at the cursor position.

- ◆ Each time the [▲] key is pressed, the value increases. Holding down the [▲] key will cause the value to increase continuously.
- Lv must consist of 4 or less digits, so extra digits will be discarded.
- ◆ To cancel entry of the target data, press the **SELECT/CANCEL** key.

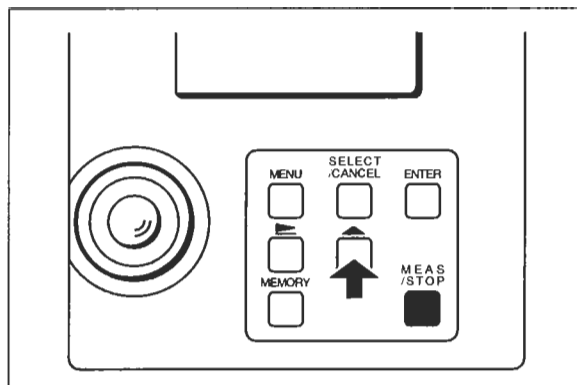

6. Press the **ENTER** key.

- ◆ "SAVE OK?" message will appear as shown below.

SAVE OK?	T1	
Yes	:	ENTER
No	:	CANCEL

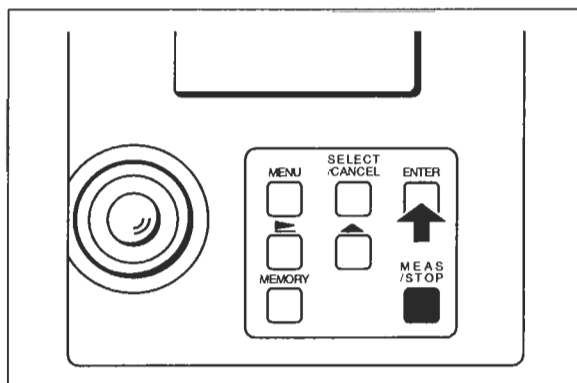

7. To save the target data, press the **ENTER** key.

- ◆ The target data will be saved.
- If target data already exists in the selected memory No., it will be replaced with the new target data. If the data existing in the memory is measured data, the selected observer's data will be overwritten and the other data will be deleted.
- If you do not want to save the data, press the **SELECT/CANCEL** key.

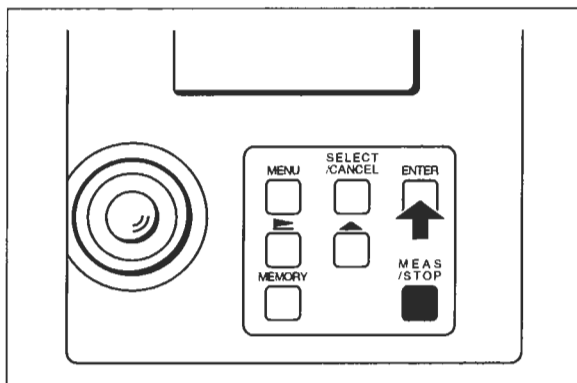

8. Press the **MEMORY** key.

- ◆ The target data will be set.

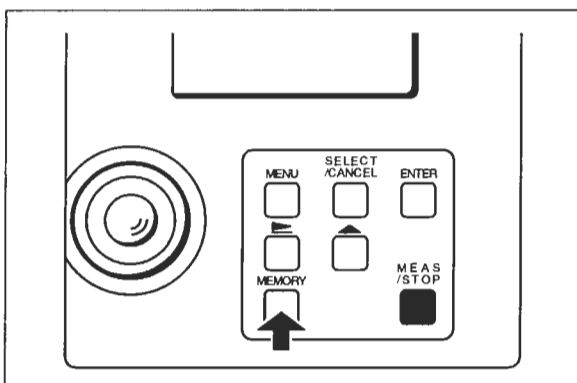

Each target data (Lvxy and Lvu'v') must be set so that the following conditions are met. If not, "DATA SET ERROR" message will appear.

- ① $Lv \geq 0.01$
- ② $x \geq 0.001, y \geq 0.0001$
- ③ $x + y \leq 0.9999$
- ④ $u' \geq 0.0001, v' \geq 0.0001$

<REFERENCE>

The relationship between $u'v'$ and xy is given below.

$$u' = \frac{4x}{-2x+12y+3} \qquad x = \frac{4.5u'}{3u'-8v'+6}$$
$$v' = \frac{9x}{-2x+12y+3} \qquad y = \frac{2v'}{3u'-8v'+6}$$

Deleting Measured Data

This section describes how to delete saved measured data.

1. Press the **MEMORY** key.

- ◆ The memory screen will appear.
- ◆ "SAVE MEAS" message will appear.

▶ SAVE MEAS	:	M1
Lv =		123.4cd/m ²
x =		0.1567
y =		0.2356

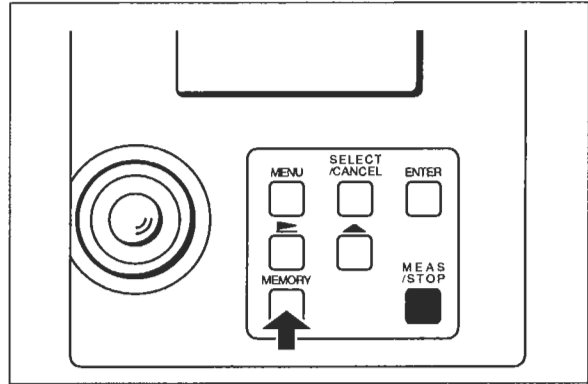

2. Keep pressing the [**▲**] key until the memory no. from which the measured data is to be deleted is displayed.

- ◆ Each time the [**▲**] key is pressed, memory no. switches in the order M1, M2, M3 up to M30 and back to M1. Holding down the [**▲**] key will cause the memory no. to change continuously.

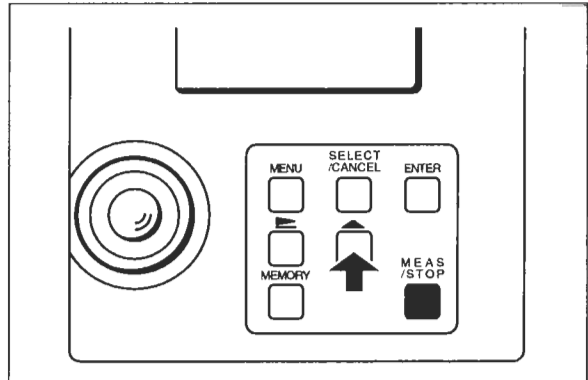

3. While holding down the [**▶**] key, press the **ENTER** key.

- ◆ "DELETE OK?" message will appear.

DELETE OK?		M1
Yes	:	ENTER
No	:	CANCEL

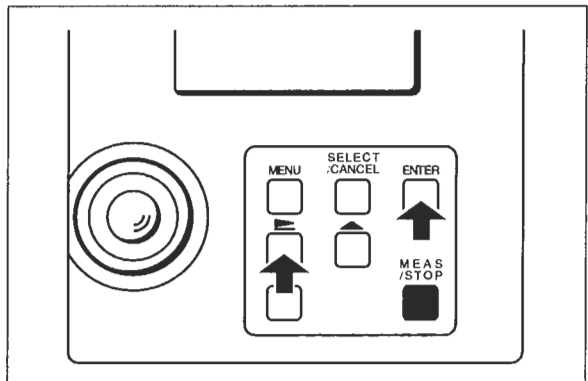

4. To delete the measured data, press the **ENTER** key.

- ◆ The measured data will be deleted.

```
▶ SAVE MEAS : M1
Lv =
x =
y =
```

- If you do not want to save the data, press the **SELECT/CANCEL** key.

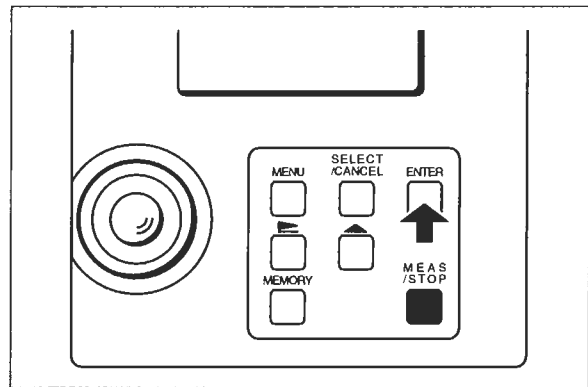

5. Press the **MEMORY** key.

- ◆ The measurement screen will reappear.

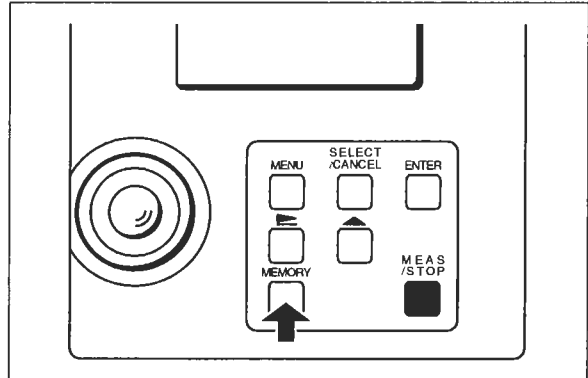

Deleting Target Data

This section describes how to delete saved target data.

If the selected target data is measured data, both data for 2° and 10° will be deleted. If the selected target data is the data you have input directly, only the data for the selected observer will be deleted, and the other data will not.

1. Press the **MEMORY** key.

- ◆ The memory screen will appear.
- ◆ "SAVE MEAS" message will appear.

▶	SAVE MEAS	:	M1
	Lv =		103.4cd/m ²
	x =		0.1567 ..
	y =		0.2756

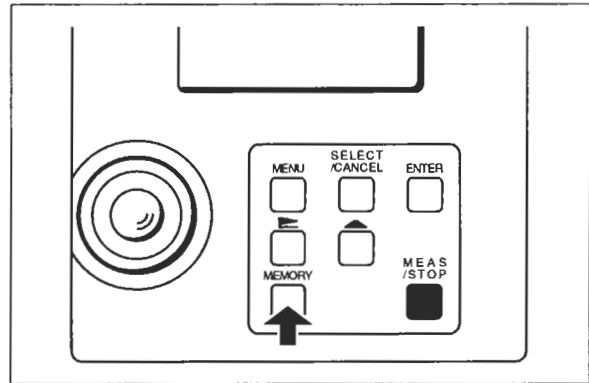

2. Press the **SELECT/CANCEL** key.

- ◆ Each time the **SELECT/CANCEL** key is pressed, the message switches in the following order.

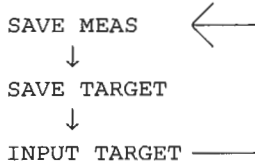

- ◆ "SAVE TARGET" message will appear.

▶	SAVE MEAS	:	T1
	Lv =		167.4cd/m ²
	x =		0.1546
	y =		0.1658

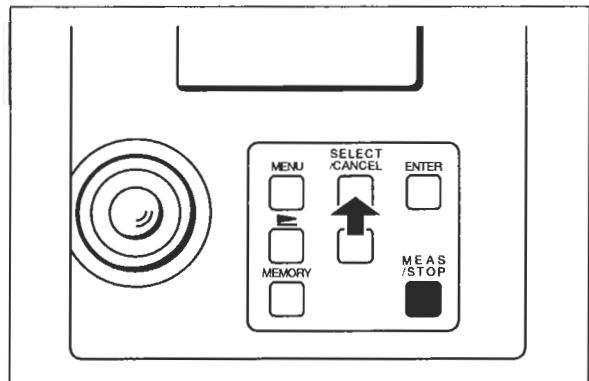

3. Keep pressing the **[▲]** key until the memory no. from which the target data is to be deleted is displayed.

- ◆ Each time the **[▲]** key is pressed, memory no. switches in the order T1, T2, T3 up to T20 and back to T1. Holding down the **[▲]** key will cause the memory no. to change continuously.

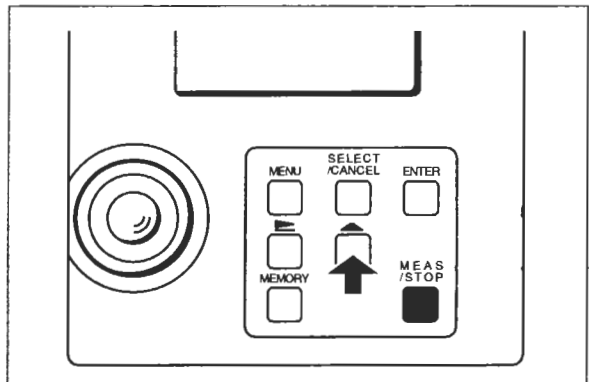

4. While holding down the [▶] key, press the **ENTER** key.

◆ "DELETE OK?" message will appear.

DELETE OK?	T1
Yes	: ENTER
No	: CANCEL

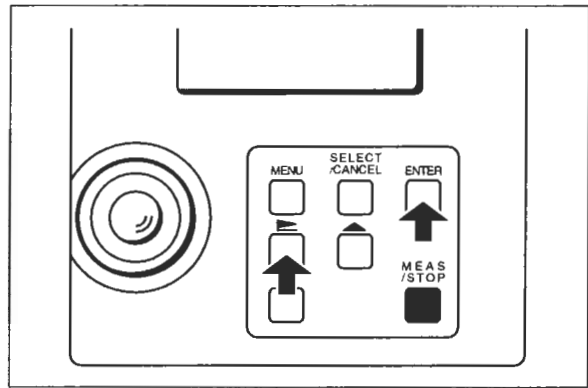

5. To delete the target data, press the **ENTER** key.

◆ The target data will be deleted.

▶ SAVE TARGET :	T1
Lv =	
x =	
y =	

● If you do not want to save the data, press the **SELECT/CANCEL** key.

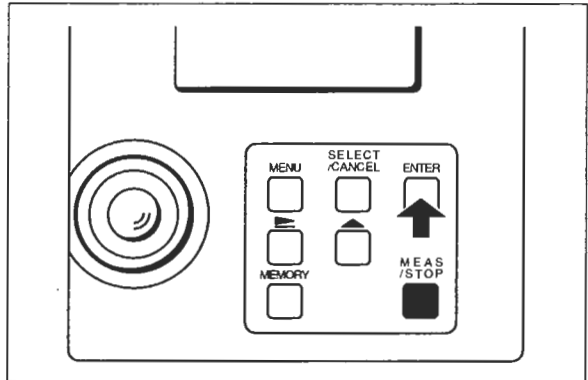

6. Press the **MEMORY** key.

◆ The measurement screen will reappear.

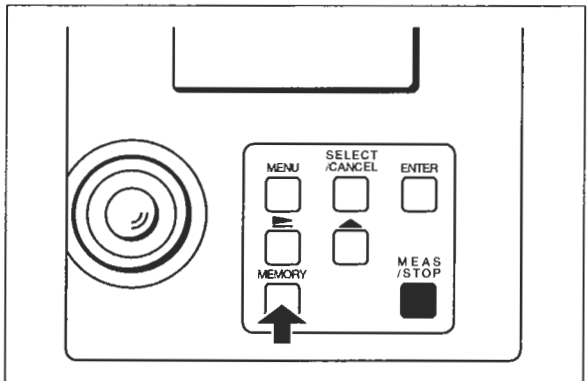

Displaying Color Difference/Relative Luminance

This section describes how to display color difference/relative luminance between measured data or saved measured data and target data.

- Color difference/relative luminance can be displayed only when Lvxy or Lvu'v' display mode is selected.
- Before carrying out the following procedure, set the desired measured data or target data. If no measured data or target data has been set, an error message will appear when the following procedure is carried out. (Refer to "ERROR MESSAGES" on page 80.)

For Measured Data

1. First, save the target data to be compared with the measured data into the desired memory no., and set it. (See pages 30 to 31.)
2. Select color difference display mode (DIFF). (See page 21.)
3. After the target data has been saved and DIFF has been selected, press the **MENU** key.

◆ The measurement display will appear.

4. Start measurement.

◆ The color difference or relative luminance in relation to the target data set in step 1 will be displayed.

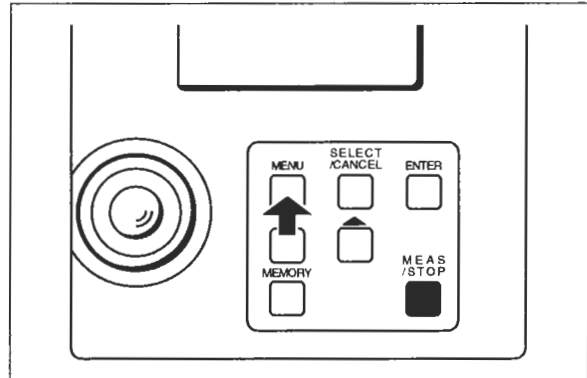

5. To switch the target data to another, press the [▲] key after completion of measurement.

◆ Each time the [▲] key is pressed, the target data switches from one to another in the order T3, T4 up to T20 and then to T1, causing the color difference or relative luminance in relation to the selected target data to be displayed. Holding down the [▲] key will cause the memory no. to switch continuously. (e.g.) For target data (T2)

AUTO.		(T2)
Lv%	=	98.76%
Δx	=	-0.0123
Δy	=	+0.0123

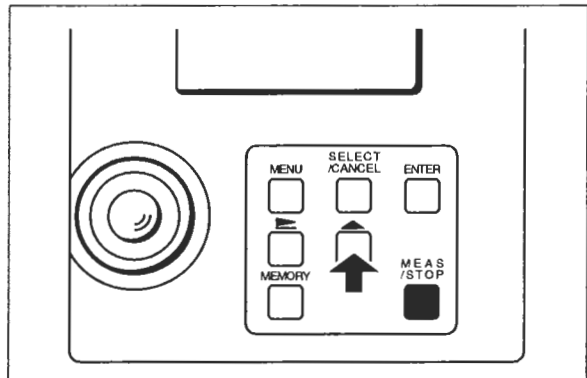

- To display the absolute value of the measured data, select absolute value display mode (ABS) instead of color difference display mode (DIFF) in step 2.

For Saved Measured Data

1. Save the measured data and target data to be compared with each other into the desired memory no. (See pages 30 to 31.)
2. Select color difference display mode (DIFF). (See page 21.)
3. Press the **MEMORY** key.

- The color difference/relative luminance between the measured data (M1) and target data (T2) will be displayed.
(e.g.) For measured data (M1) and target data (T1)

▶ SAVE MEAS		M1 (T1)
Lv%	=	98.76%
Δx	=	-0.0123
Δy	=	+0.0123

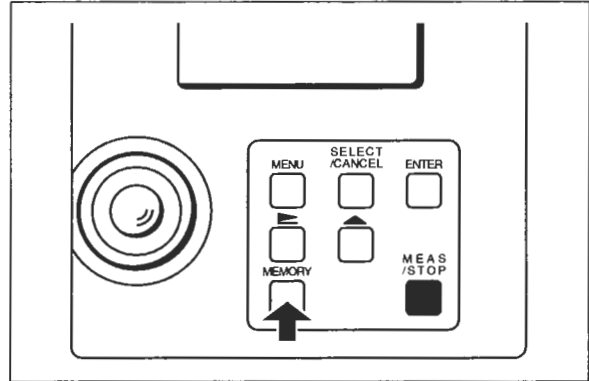

Switching the Measured Data to Another

4. Press the [\blacktriangle] key.

- ◆ Each time the [\blacktriangle] key is pressed, the target data switches from one to another in the order M3, M4 up to M20 and then to M1, causing the color difference or relative luminance in relation to the selected target data to be displayed. Holding down the [\blacktriangle] key will cause the memory no. to switch continuously.
(e.g.) For measured data (M1) and target data (T1)

▶ SAVE MEAS		M2 (T1)
Lv%	=	98.76%
Δx	=	-0.0123
Δy	=	+0.0123

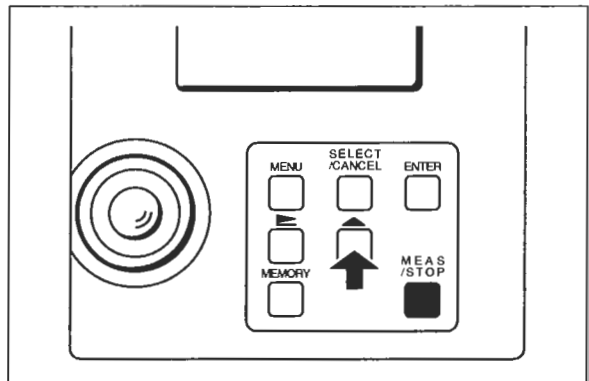

Switching the Target data to Another

5. Press the **SELECT/CANCEL** key.

- ◆ The memory screen will appear, and "SAVE TARGET" message appears.

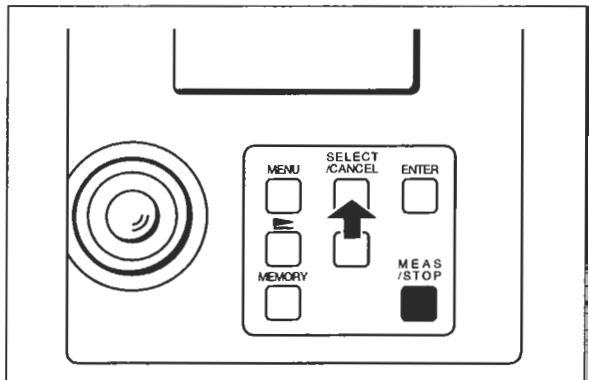

6. Press the [▲] key.

- Each time the [▲] key is pressed, the target data switches from one to another in the order T3, T4 up to T20 and then to T1, causing the color difference or relative luminance in relation to the selected target data to be displayed.

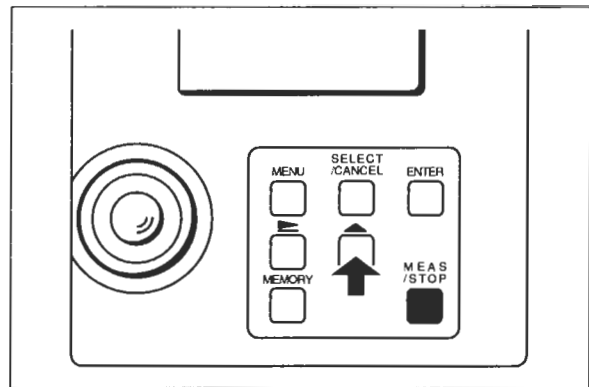

7. Press the **SELECT** key twice.

- The SAVEMEAS screen will reappear, displaying the color difference/relative luminance.

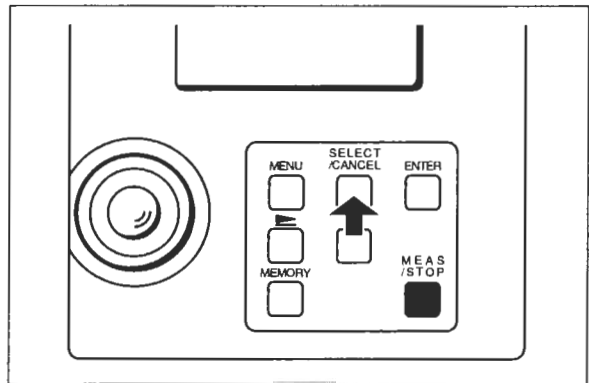

Communication

CONNECTING THE CS-1000A TO A PERSONAL COMPUTER

A 9-pin Dsub connector is provided on the CS-1000A so that the CS-1000A can be communicated with a personal computer.

Use a RS-232C cable to connect the CS-1000A to a personal computer.

- When connecting the connectors, make sure that they are correctly oriented.
- Do not touch the connector terminals with your hands or allow them to get dirty.
- Be sure that the cable has at least a small amount of slack. Stretching the cable tight may cause connection failure or wire breakage.

Pin Assignment of RS-232C Cable

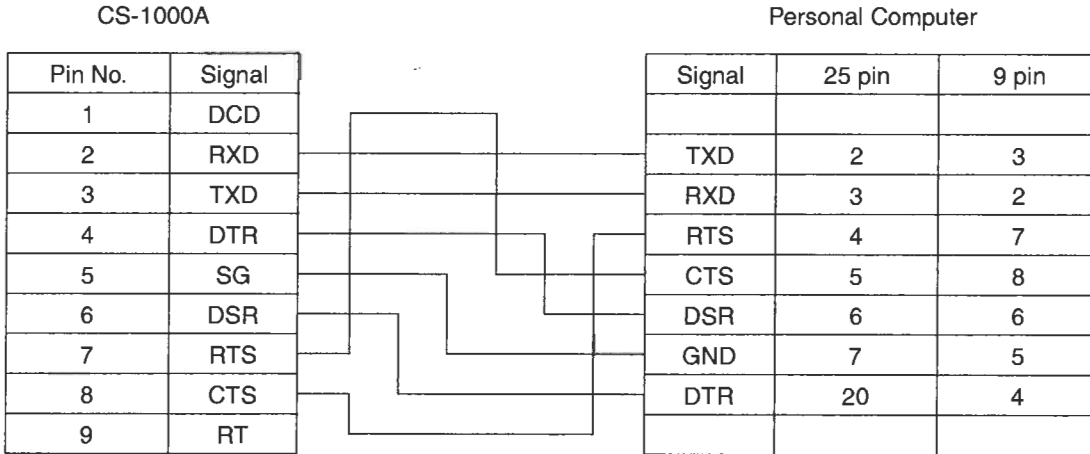

<Setting the Communication Parameters>

Set each communication parameter as described below.

- X parameter : Not valid
- Data bit : 8 bits
- Stop bit : 1 bit
- Parity check : None
- Baud rate : 4800, 9600, 19200 (must be the same as the baud rate set on the CS-1000A)

1. Set the POWER switch of both CS-1000A and personal computer to OFF.
2. Connect the RS-232C cable to the RS-232C terminal provided on the CS-1000A.

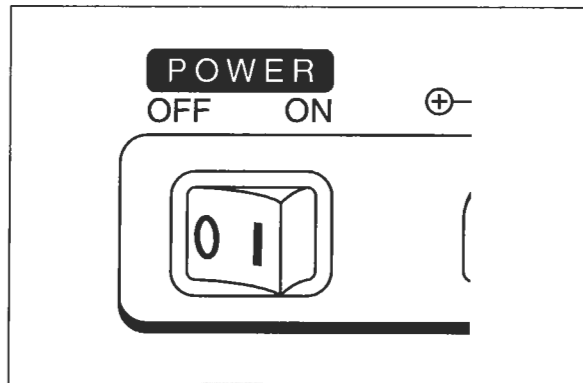

3. Set the POWER switch of the CS-1000A to ON.
4. Set the baud rate of the CS-1000A. (See page 23.)
5. Set the POWER switch of the personal computer to ON.

- "Remote on" message will appear on the LCD of the CS-1000A while the CS-1000A is controlled by the personal computer via the RS-232C interface. While this message is displayed, it is not possible to operate any keys on the CS-1000A. If you need to operate keys because the baud rate needs to be changed or for other reasons, press the MEAS./STOP key to cancel remote mode. Resuming operation of the CS-1000A through the personal computer will put the CS-1000A in remote mode again, causing "Remote on" message to appear on the LCD once again.

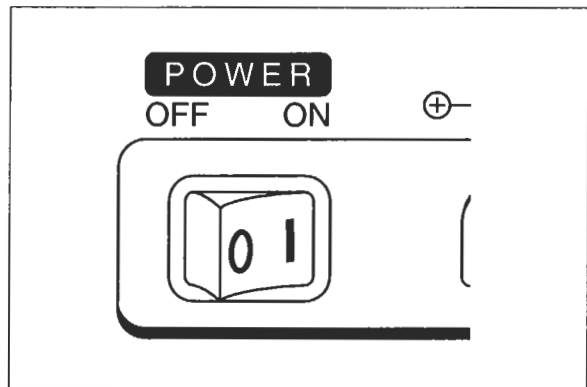

COMMAND LIST

Command	Function
RMT	Turns remote mode on/off
SPS	Switches the measuring speed from one to another.
SPR	Outputs the selected measuring.
MES	Starts and stops measurement.
MMS	Switches measurement mode from one to another. Requires the user to set the frequency if INT.SYNC measurement mode is selected, or the integration time if MAN. measurement mode is selected.
STR	Reads the status information of the CS-1000A.
BDR	Reads the measured data.
MDR	Reads the specified saved measured data.
TDR	Reads the specified saved target data.
MDD	Deletes the specified saved measured data.
TDD	Deletes the specified saved target data.
TDS	Transfers and saves the specified target data to the memory of the CS-1000A.

DELIMITER CODE

When inputting a command from the personal computer, a delimiter code must be input after the command. However, when inputting a command (e.g., TDS) which is to be accompanied by data, be sure to input a delimiter code after all the data has been input.

1. CR (Carriage Return)
2. LF (Line Feed)
3. CR LF (CR and LF)

The CS-1000A recognizes any of the above codes as a delimiter code (by using the automatic delimiter code detection function).

The same delimiter code as for the input command will be used for the output data.

INPUT/OUTPUT FORMAT

"#" and values appearing in descriptions of commands must be input in text format.

ERROR CHECK CODES

OK CODE

Code	Description	Corrective Action
OK	Processed successfully	

Error Code

Code	Description	Corrective Action
ER00	An invalid command name was input.	Input the correct command name.
	An invalid command was input.	Input the correct command.
	The command was altered.	Check the communication parameters.
ER01	Invalid command parameter was set.	Set the correct command parameter.
ER02	The command was not accepted since measurement was in progress.	Input the command after the output data is received following completion of measurement.
ER03	Overrun error or framing error has occurred.	Check the communication parameters.
ER10	The measured spectral value was outside the measuring range.	For MAN measurement mode, decrease the integration time so that no UNDER error appears. If the integration time is already set to 40 ms or this error occurs in AUTO measurement mode, decrease the luminance of the object. Stabilize luminance of the object, or switch to MAN mode and set longer integration time within the range in which no UNDER error occurs. To measure a display, switch to INT.SYNC or EXT.SYNC mode.
	For MAN measurement mode, a value 1.2 times the integration time set in AUTO measurement mode or higher was set for a light source whose luminance was within the measuring range.	
	It was not possible to set static integration time for AUTO measurement mode due to extreme fluctuation of luminance of the object.	
ER11	No external vertical sync. signal was input in EXT.SYNC measurement mode.	Input a vertical sync. signal having an appropriate frequency to the BNC terminal of the CS-1000A.
	The frequency of external vertical sync. signal was outside the allowable range (20 to 250 Hz).	
ER12	No objective lens was attached.	Attach the objective lens supplied with the CS-1000A.
	An objective lens other than the one supplied with the CS-1000A was attached.	
ER20	Attempted to read data, but no data was present.	
ER21	No spectral radiant luminance data was present, since the target data saved in the selected memory no. was manually entered data.	
	Attempted to read the other observer of target data which was not manually entered.	Set the right observer's target data which was not manually entered.
ER30 - ER34	Electric circuit was not operating properly.	Set the POWER switch to OFF, then set it to ON. If the same error still occurs, contact the nearest Minolta authorized service facility.

INPUT/OUTPUT FORMAT OF EACH COMMAND

When a command is transmitted according to the specified input format, the CS-1000A will perform the specific functions of that command, and reply according to the specified output format.

<RMT>

Turns remote mode on/off.

To control the CS-1000A through the personal computer, remote mode must be turned on. Once remote mode is activated, other commands can be sent to the CS-1000A.

This command is also used to turn off remote mode to isolate control of the CS-1000A from the personal computer.

Input Format

The command must be specified in the following format.

RMT, * Delimiter code
(see page 48)

① Remote mode ON/OFF ----- Remote mode OFF: "0"
Remote mode ON: "1"

Output Format

The data is output in the following format. No data will be output if remote mode is off.

In case of no error

OK

Delimiter code
(see page 48)

In case of error

Error check code
(see page 49)

Delimiter code
(see page 48)

<SPS>

Input Format

SPS, * Delimiter code
(see page 48)
|
①
① Measurement speed ----- NORMAL: "0"
FAST: "1"

Output Format

In case of no error

OK Delimiter code
(see page 48)

In case of error

Error check code
(see page 49) Delimiter code
(see page 48)

<SPR>

Input Format

SPR Delimiter code
(see page 48)

Output Format

In case of no error

OK, * Delimiter code
(see page 48)
|
①
① Measurement speed ----- NORMAL: "0"
FAST: "1"

In case of error

Error check code
(see page 49) Delimiter code
(see page 48)

In case of output data 1 is error

OUTPUT DATA 1

Error check code
(see page 49)

Delimiter code
(see page 48)

In case of measurement error 1, the command is transferred from the personal computer to the CS-1000A, but no data is output from the CS-1000A.

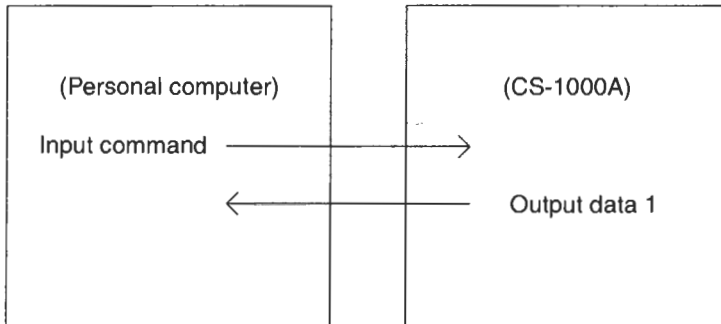

In case of output data 2 is error

OUTPUT DATA 1

MES,

*

|

①

Delimiter code
(see page 48)

① Integration time ----- (in units of seconds): ##.###

OUTPUT DATA 2

Error check code
(see page 49)

Delimiter code
(see page 48)

In case of output data 2 is error, the command, data 1 and data 2 are transferred between the CS-1000A and personal computer as shown below.

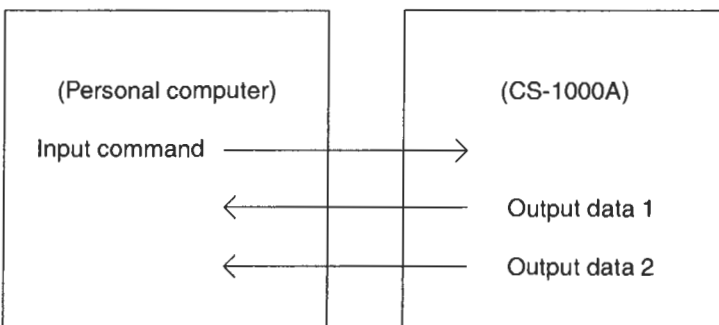

<MMS>

Switches measurement mode of the CS-1000A from one to another. It is necessary to set the frequency if INT.SYNC measurement mode is selected, or the integration time if MAN. measurement mode is selected.

Input Format

The command must be specified in the following format.

MMS, * * Delimiter code
(see page 48)
 | |
 ① ②

① Measurement mode

AUTO : "0"
INT. : "1"
EXT. : "2"
MAN. : "3"

② Frequency or integration time --- AUTO : Not necessary to set.

INT. : Frequency (in units of Hz)

● Setting range: 20.00 to 250.00 Hz

● Up to 6 digits including the decimal point

● Third place below the decimal point is rounded off.

EXT. : Not necessary to set.

MAN. : Integration time (in units of seconds)

● Setting range: 0.040 to 60.000 seconds

● Up to 6 digits including the decimal point

● Fourth place below the decimal point is rounded off.

Output Format

The data is output in the following format.

In case of no error

OK

Delimiter code
(see page 48)

In case of error

Error check code
(see page 49)

Delimiter code
(see page 48)

<STR>

Reads the status of the CS-1000A.

Input Format

The command must be specified in the following format.

STR

Delimiter code (see page 48)

Output Format

The data is output in the following format.

In case of no error

OK, *, *, *, *, *, *, *,

① ② ③ ④ ⑤ ⑥ ⑦

Delimiter code (see page 48)

① Measurement mode	AUTO : "0" INT. : "1" EXT. : "2" MAN. : "3"
② Frequency	(INT. measurement mode only) ◆ ###.## ◆ In units of Hz
③ Integration time	(MAN. measurement mode only) ◆ ##.### ◆ In units of seconds
④ Display mode	Lvxy : "0" Lvu'v' : "1" LvTΔuv : "2"
⑤ Absolute value/color difference display	ABS. : "0" DIFF : "1"
⑥ Observer angle	2° : "0" 10° : "1"
⑦ Lens type	Standard : "0" Macro : "1" Lens error : "2" Small area : "3" Small angle : "4"

In case of error

Error check code (see page 49)

Delimiter code (see page 48)

<BDR>

Reads the measured data from the CS-1000A.

Input Format

The command must be specified in the following format.

Input command 1

BDR, *, *, *,
| | |
① ② ③

Delimiter code
(see page 48)

- | | |
|------------------------|--|
| ① Data display | Spectral radiance : "0"
Colorimetric data : "1" |
| ② Observer angle | 2° : "0"
10° : "1" |
| ③ Readout format | Text : "0"
Binary : "1" |

Input command 2

Used to request output of the next data.

& Delimiter code
(see page 48)

Output Format (for spectral radiance data in binary format)

Spectral radiant luminance data is output in the following format if it is binary data.

OUTPUT DATA 1

In case of no error

OK, *, *, *, *,
 | | | | |
 ① ② ③ ④

Delimiter code
(see page 48)

- ① Measurement mode AUTO (NORMAL) : "0"
 INT. (NORMAL) : "1"
 EXT. (NORMAL) : "2"
 MAN. (NORMAL) : "3"
 AUTO (FAST) : "4"
 INT. (FAST) : "5"
 EXT. (FAST) : "6"
 MAN. (FAST) : "7"
- ② Integration time (MAN. measurement mode) ##.### (in units of seconds)
- ③ Lens type Standard : "0"
 Macro : "1"
 Small area : "3"
 Small angle : "4"
- ④ Under flag Sufficient exposure : "0"
 Insufficient exposure : "1"

In case of error

Error check code
(see page 49)

Delimiter code
(see page 48)

OUTPUT DATA 2 TO 8

Data 2 to 8 will not be output if an error code is output by data 1.

Output data 2	b380 b381 b382	b439	60 wavelength (240 bytes)
Output data 3	b440 b441 b442	b499	60 wavelength (240 bytes)
	⋮		
Output data 7	b680 b681 b682	b739	60 wavelength (240 bytes)
Output data 8	b740 b741 b742	b780	41 wavelength (164 bytes)

b*** ... 4-byte floating point data (IEEE format) indicating spectral radiance data of the wavelength

In case of no error, commands and data are transferred between the CS-1000A and personal computer as shown below.

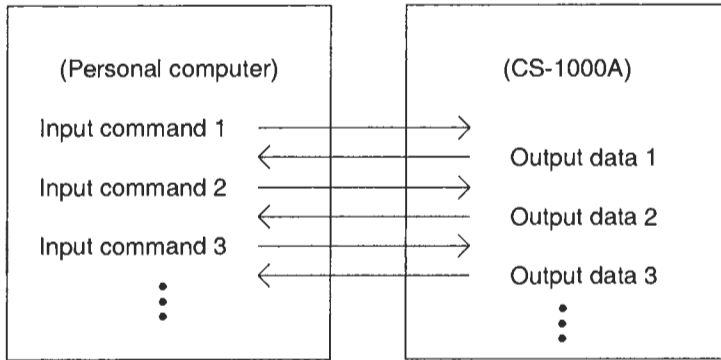

Output Format (for spectral radiance data in text format)

Spectral radiant luminance data is output in the following format if it is text data.

OUTPUT DATA 1

In case of no error

OK, *, *, *, *,
 | | | | |
 ① ② ③ ④

Delimiter code
(see page 48)

- ① Measurement mode AUTO (NORMAL) : "0"
 INT. (NORMAL) : "1"
 EXT. (NORMAL) : "2"
 MAN. (NORMAL) : "3"
 AUTO (FAST) : "4"
 INT. (FAST) : "5"
 EXT. (FAST) : "6"
 MAN. (FAST) : "7"
- ② Integration time ##.### (in units of seconds)
- ③ Lens type Standard : "0"
 Macro : "1"
 Small area : "3"
 Small angle : "4"
- ④ Under flag Sufficient exposure : "0"
 Insufficient exposure : "1"

In case of error

Error check code
(see page 49)

Delimiter code
(see page 48)

OUTPUT DATA 2 TO 16

Data 2 to 16 will not be output if an error code is output by data 1.

Output data 2	t308	t381	t382	t407	Delimiter code (see page 48)	28 wavelength (251 bytes + Delimiter code)
Output data 3	t408	t409	t410	t435	Delimiter code (see page 48)	28 wavelength (251 bytes + Delimiter code)
				⋮			
Output data 15	t744	t745	t746	t771	Delimiter code (see page 48)	28 wavelength (251 bytes + Delimiter code)
Output data 16	t772	t773	t774	t780	Delimiter code (see page 48)	9 wavelength (80 bytes + Delimiter code)

t*** Text data ("###e+/-#") indicating spectral radiance data of the wavelength

In case of no error, commands and data are transferred between the CS-1000A and personal computer as shown below.

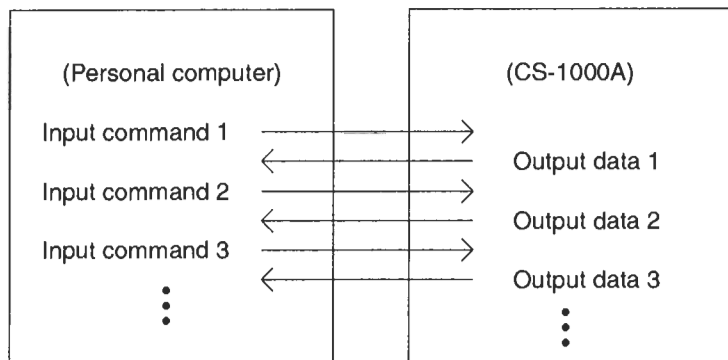

Output Format (for colorimetric data in text format)

OUTPUT DATA 1

In case of no error

OK, *, *, *, *,
 | | | |
 ① ② ③ ④

Delimiter code
 (see page 48)

① Measurement mode..... AUTO (NORMAL) : "0"
 INT. (NORMAL) : "1"
 EXT. (NORMAL) : "2"
 MAN. (NORMAL) : "3"
 AUTO (FAST) : "4"
 INT. (FAST) : "5"
 EXT. (FAST) : "6"
 MAN. (FAST) : "7"

② Integration time..... ##.### (in units of seconds)

③ Lens type..... Standard : "0"
 Macro : "1"
 Small area: "3"
 Small angle: "4"

④ Under flag..... Sufficient exposure : "0"
 Insufficient exposure : "1"

In case of error

Error check code
 (see page 40)

Delimiter code
 (see page 39)

OUTPUT DATA 2

Data 2 will not be output if an error code is output by data 1.

Le, Lv, X, Y, Z, x, y, u', v', T, Δuv
 | | | | | | | | | | |
 ⑤ ⑥ ⑦ ⑧ ⑨ ⑩ ⑪ ⑫ ⑬ ⑭ ⑮

Delimiter code
 (see page 48)

⑤ Le #.###e±#
 ⑥ Lv #####
 ⑦ X #.###e±#
 ⑧ Y #.###e±#
 ⑨ Z #.###e±#
 ⑩ x 0.####
 ⑪ y 0.####
 ⑫ u' 0.####
 ⑬ v' 0.####
 ⑭ T #####
 ⑮ Δuv ±0.####

(Note) "*****" will be displayed in case of display range over.

(Note) "**.*" will be displayed in case of display range over.

In case of no error, commands and data are transferred between the CS-1000A and personal computer as shown below.

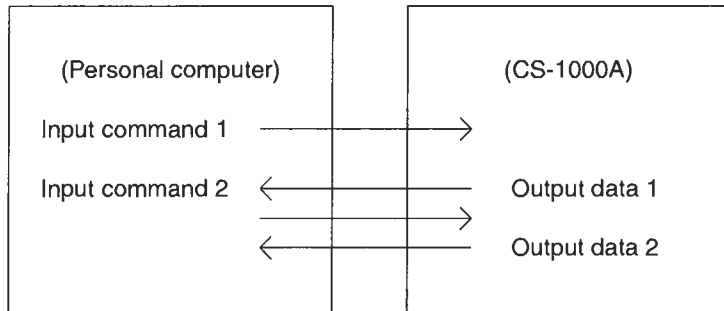

<MDR>

Reads the specified measured data saved on the CS-1000A.

Input Format

The command must be specified in the following format.

INPUT COMMAND 1

MDR, *, *, *, *, Delimiter code
(see page 48)

① ② ③ ④

- | | |
|---------------------------------|---|
| ① Data display | Spectral radiance : "0"
Colorimetric data : "1" |
| ② Observer angle | 2° : "0"
10° : "1" |
| ③ Readout format | Text : "0"
Binary : "1" |
| ④ Measured data memory no. | Integer (1 or 2 digits) : ##
● Setting range : 1 to 30 |

INPUT COMMAND 2

Used to request output of the next data.

& Delimiter code
(see page 48)

Output Format (for spectral radiant luminance data in binary format)

Spectral radiance data is output in the following format if it is binary data.

OUTPUT DATA 1

In case of no error

OK, *, *, *, *, Delimiter code
(see page 48)

① ② ③ ④

- | | |
|--------------------------|--|
| ① Measurement mode | AUTO (NORMAL) : "0"
INT. (NORMAL) : "1"
EXT. (NORMAL) : "2"
MAN. (NORMAL) : "3"
AUTO (FAST) : "4"
INT. (FAST) : "5"
EXT. (FAST) : "6"
MAN. (FAST) : "7" |
| ② Integration time | ##.### (in units of seconds) |
| ③ Lens type | Standard : "0"
Macro : "1"
Small area : "3"
Small angle : "4" |
| ④ Under flag | Sufficient exposure : "0"
Insufficient exposure : "1" |

In case of error

Error check code
(see page 49)

Delimiter code
(see page 48)

OUTPUT DATA 2 TO 8

If an error code occurs during output of data, that data and subsequent data will not be output.

Output data 2	b380 b381 b382	b439	60 wavelength (240 bytes)
Output data 3	b440 b441 b442	b499	60 wavelength (240 bytes)
		⋮	
Output data 7	b680 b681 b682	b739	60 wavelength (240 bytes)
Output data 8	b740 b741 b742	b789	41 wavelength (164 bytes)

b*** ⋮ 4-byte floating point data (IEEE format) indicating spectral radiance data of the wavelength

In case of no error, commands and data are transferred between the CS-1000A and personal computer as shown below.

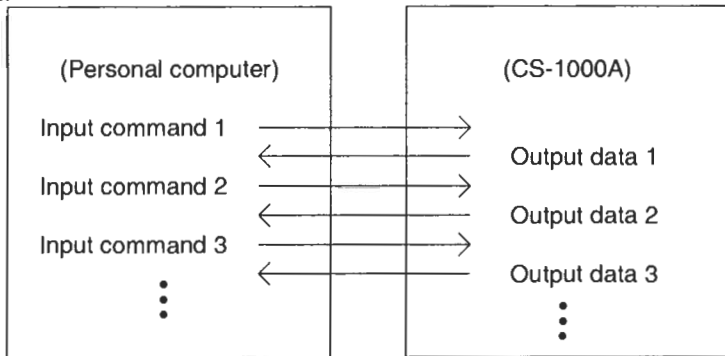

Output Format (for spectral radiance data in text format)

Spectral radiance data is output in the following format if it is text data.

OUTPUT DATA 1

In case of no error

OK, *, *, *, *,
 | | | |
 ① ② ③ ④

Delimiter code
(see page 48)

- ① Measurement mode..... AUTO (NORMAL) : "0"
 INT. (NORMAL) : "1"
 EXT. (NORMAL) : "2"
 MAN. (NORMAL) : "3"
 AUTO (FAST) : "4"
 INT. (FAST) : "5"
 EXT. (FAST) : "6"
 MAN. (FAST) : "7"
- ② Integration time..... ##.### (in units of seconds)
- ③ Lens type..... Standard : "0"
 Macro : "1"
 Small area: "3"
 Small angle: "4"
- ④ Under flag..... Sufficient exposure : "0"
 Insufficient exposure : "1"

In case of error

Error check code
(see page 49)

Delimiter code
(see page 48)

OUTPUT DATA 2 TO 16

If an error code occurs during output of data, that data and subsequent data will not be output.

- Output data 2 t380 t381 t382 t407 Delimiter code
(see page 48) 28 wavelength (251 bytes + Delimiter code)
- Output data 3 t408 t409 t410 t435 Delimiter code
(see page 48) 28 wavelength (251 bytes + Delimiter code)
- Output data 15 t744 t745 t746 t771 Delimiter code
(see page 48) 28 wavelength (251 bytes + Delimiter code)
- Output data 16 t772 t773 t774 t780 Delimiter code
(see page 48) 9 wavelength (80 bytes + Delimiter code)

t*** Text data ("#.###e+/-#") indicating spectral radiance data of the wavelength

In case of no error, commands and data are transferred between the CS-1000A and personal computer as shown below.

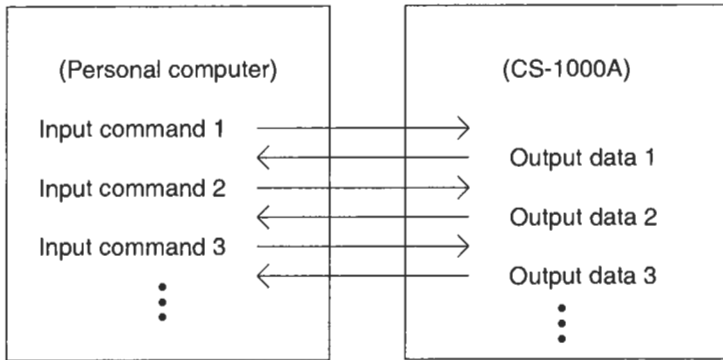

Output Format (for colorimetric data in text format)

OUTPUT DATA 1

In case of no error

OK, *, *, *, *,
 | | | | |
 ① ② ③ ④

Delimiter code
 (see page 48)

- ① Measurement mode AUTO (NORMAL) : "0"
 INT. (NORMAL) : "1"
 EXT. (NORMAL) : "2"
 MAN. (NORMAL) : "3"
 AUTO (FAST) : "4"
 INT. (FAST) : "5"
 EXT. (FAST) : "6"
 MAN. (FAST) : "7"
- ② Integration time ##.### (in units of seconds)
- ③ Lens type Standard : "0"
 Macro : "1"
 Small area: "3"
 Small angle: "4"
- ④ Under flag Sufficient exposure : "0"
 Insufficient exposure: "1"

In case of error

Error check code
 (see page 49)

Delimiter code
 (see page 48)

OUTPUT DATA 2

Data 2 will not be output if an error code is output by data 1.

Le, Lv, X, Y, Z, x, y, u', v', T, Δuv
 | | | | | | | | | | | |
 ⑤ ⑥ ⑦ ⑧ ⑨ ⑩ ⑪ ⑫ ⑬ ⑭ ⑮

Delimiter code
 (see page 48)

- ⑤ Le #.###e±#
 ⑥ Lv #####
 ⑦ X #.###e±#
 ⑧ Y #.###e±#
 ⑨ Z #.###e±#
 ⑩ x 0.####
 ⑪ y 0.####
 ⑫ u' 0.####
 ⑬ v' 0.####
 ⑭ T #####
 ⑮ Δuv ±0.####

(Note) "*****" will be displayed in case of display range over.

(Note) "**.*****" will be displayed in case of display range over.

In case of no error, commands and data are transferred between the CS-1000A and personal computer as shown below.

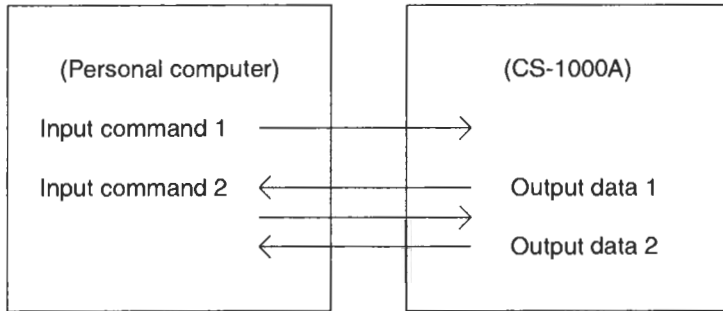

<TDR>

Input Format

The command must be specified in the following format.

TDR, *, *, *, *, Delimiter code
(see page 48)

| | | |

① ② ③ ④

- ① Data display Spectral radiance : "0"
Colorimetric data : "1"
- ② Observer angle 2° : "0"
10° : "1"
- ③ Readout format Text : "0"
Binary : "1"
- ④ Target data memory no. Integer (2 digits) : ##
● Setting range : 1 to 30

INPUT COMMAND 2

The command must be specified in the following format.

& Delimiter code
(see page 48)

Output Format (for spectral radiance data in binary format)

Spectral radiance data is output in the following format if it is binary data.

OUTPUT DATA 1

In case of no error

OK, *, *, *, *, Delimiter code
(see page 48)

| | | |

① ② ③ ④

- ① Measurement mode AUTO (NORMAL) : "0"
INT. (NORMAL) : "1"
EXT. (NORMAL) : "2"
MAN. (NORMAL) : "3"
AUTO (FAST) : "4"
INT. (FAST) : "5"
EXT. (FAST) : "6"
MAN. (FAST) : "7"
- ② Integration time ##.### (in units of seconds)
- ③ Lens type Standard : "0"
Macro : "1"
Small area : "3"
Small angle : "4"
- ④ Under flag Sufficient exposure : "0"
Insufficient exposure : "1"

In case of error

Error check code
(see page 49)

Delimiter code
(see page 48)

OUTPUT DATA 2 TO 8

If an error code occurs during output of data, that data and subsequent data will not be output.

Output data 2	b380 b381 b382	b439	60 wavelength (240 bytes)
Output data 3	b440 b441 b442	b499	60 wavelength (240 bytes)
		⋮	
Output data 7	b680 b681 b682	b739	60 wavelength (240 bytes)
Output data 8	b740 b741 b742	b789	41 wavelength (164 bytes)

b***

4-byte floating point data (IEEE format) indicating spectral radiance data of the wavelength

In case of no error, commands and data are transferred between the CS-1000A and personal computer as shown below.

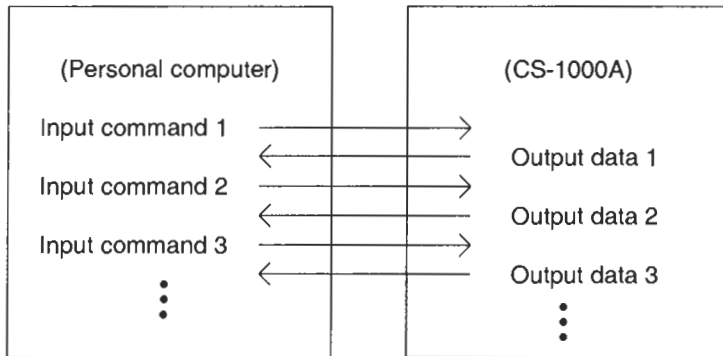

Output Format (for spectral radiance data in text format)

Spectral radiant luminance data is output in the following format if it is text data.

OUTPUT DATA 1

In case of no error

OK,	*	*	*	*	Delimiter code (see page 48)
	①	②	③	④	

- | | |
|--------------------------|--|
| ① Measurement mode | AUTO (NORMAL) : "0"
INT. (NORMAL) : "1"
EXT. (NORMAL) : "2"
MAN. (NORMAL) : "3"
AUTO (FAST) : "4"
INT. (FAST) : "5"
EXT. (FAST) : "6"
MAN. (FAST) : "7" |
| ② Integration time | ###.### (in units of seconds) |
| ③ Lens type | Standard : "0"
Macro : "1"
Small area: "3"
Small angle: "4" |
| ④ Under flag | Sufficient exposure : "0"
Insufficient exposure : "1" |

In case of error

Error check code (see page 49)	Delimiter code (see page 48)
-----------------------------------	---------------------------------

OUTPUT DATA 2 TO 16

If an error code occurs during output of data, that data and subsequent data will not be output.

Output data 2	t308	t381	t382	t407	Delimiter code (see page 48)	28 wavelength (251 bytes + Delimiter code)
Output data 3	t408	t409	t410	t435	Delimiter code (see page 48)	28 wavelength (251 bytes + Delimiter code)
				⋮			
Output data 15	t744	t745	t746	t771	Delimiter code (see page 48)	28 wavelength (251 bytes + Delimiter code)
Output data 16	t772	t773	t774	t780	Delimiter code (see page 48)	9 wavelength (80 bytes + Delimiter code)

t*** Text data ("###.###e+/-#") indicating spectral radiance data of the wavelength

In case of no error, commands and data are transferred between the CS-1000A and personal computer as shown below.

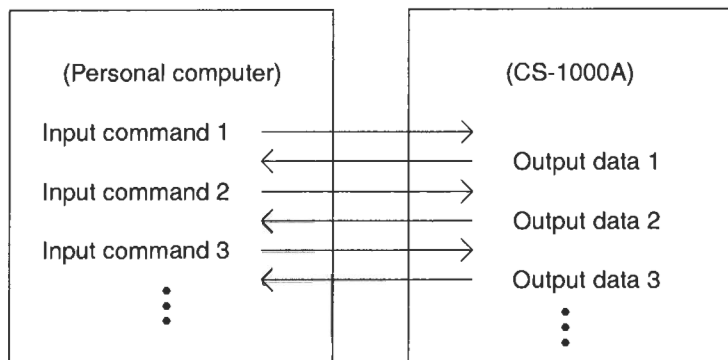

Output Format (for colorimetric data in text format)

OUTPUT DATA 1

In case of no error

OK, *	*	*	*	*	Delimiter code (see page 48)
①	②	③	④		

- | | |
|--------------------------|--|
| ① Measurement mode..... | AUTO (NORMAL) : "0"
INT. (NORMAL) : "1"
EXT. (NORMAL) : "2"
MAN. (NORMAL) : "3"
AUTO (FAST) : "4"
INT. (FAST) : "5"
EXT. (FAST) : "6"
MAN. (FAST) : "7" |
| ② Integration time | ###.### (in units of seconds) |
| ③ Lens type | Standard : "0"
Macro : "1"
Small area: "3"
Small angle: "4" |
| ④ Under flag | Sufficient exposure : "0"
Insufficient exposure : "1" |

In case of error

Error check code
(see page 49)

Delimiter code
(see page 48)

OUTPUT DATA 2

Data 2 will not be output if an error code is output by data 1.

Le,	Lv,	X,	Y,	Z,	x,	y,	u',	v',	T,	Δuv	Delimiter code (see page 48)
⑤	⑥	⑦	⑧	⑨	⑩	⑪	⑫	⑬	⑭	⑮	

- | | | |
|---------------|-------|------------|
| ⑤ Le | | ###.###e±# |
| ⑥ Lv | | ##### |
| ⑦ X | | ###.###e±# |
| ⑧ Y | | ###.###e±# |
| ⑨ Z | | ###.###e±# |
| ⑩ x | | 0.#### |
| ⑪ y | | 0.#### |
| ⑫ u' | | 0.#### |
| ⑬ v' | | 0.#### |
| ⑭ T | | ##### |
| ⑮ Δuv | | ±0.#### |

(Note) "*****" will be displayed in case of display range over.

(Note) "**.*" will be displayed in case of display range over.

In case of no error, commands and data are transferred between the CS-1000A and personal computer as shown below.

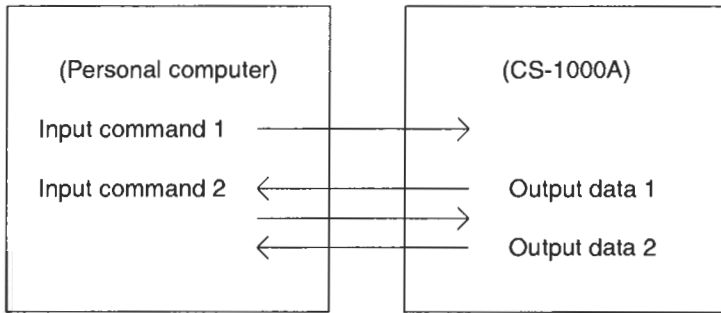

<MDD>

Deletes the specified measured data saved on the CS-1000A.

Input Format

The command must be specified in the following format.

MDD, * Delimiter code
(see page 48)
|
①

- ① Measured data memory no. -- Integer (1 or 2 digits): ##
● Setting range: 1 to 30

Output Format

In case of no error

OK

Delimiter code
(see page 48)

In case of error

Error check code
(see page 49)

Delimiter code
(see page 48)

<TDD>

Deletes the specified target data saved on the CS-1000A.

Input Format

The command must be specified in the following format.

TDD, * Delimiter code
(see page 48)
|
①

- ① Target data memory no. ----- Integer (1 or 2 digits): ##
● Setting range: 1 to 20

Output Format

The data is output in the following format.

In case of no error

OK

Delimiter code
(see page 48)

In case of error

Error check code
(see page 49)

Delimiter code
(see page 48)

<TDS>

Transfers the specified target data from the personal computer to the CS-1000A, where it is saved.

Input Format

The command must be specified in the following format.

TDS, *, *, *, *, *, *, Delimiter code
(see page 48)

① ② ③ ④ ⑤ ⑥

- ① Target data memory no. Integer (1 or 2 digits): ##
 - Setting range : 1 to 20
 - ② Observer angle 2° : "0"
 10° : "1"
 - ③ Colorimetric data xy: "0"
 u'v': "1"
 - ④ Luminance* cd/m²
 (e.g., "22.22")
 - ◆ Up to 9 characters including decimal point
 - ◆ Significant number of digits: 4 (fifth digit is rounded off)
 - ◆ Third decimal place is rounded off.
 - ⑤ Chromaticity* x or v'
 - ◆ Up to 6 characters including decimal point
 - ◆ Fifth decimal place is rounded off.
 - ⑥ Chromaticity* y or v'
 - ◆ Up to 6 characters including decimal point
 - ◆ Fifth decimal place is rounded off.
- * For Setting range, see page 36.

Output Format

The data is output in the following format.

In case of no error

OK

Delimiter code
(see page 48)

In case of error

Error check code
(see page 49)

Delimiter code
(see page 48)

Explanation

MEASUREMENT PRINCIPLE

Light energy passes through the objective lens. The lights from the measurement area pass through the hole in the center of the aperture mirror to the optical fiber, while the remaining light is guided to the finder optics by the aperture mirror. As a result, the part equivalent to the measurement area looks like a black circle when observed through the finder. The light entering the optic fiber is reflected repeatedly so that it is mixed and becomes virtually uniform. It then passes through the collimator lens to the plane diffraction grating. After being dispersed by the grating, the light is focused by the condenser lens according to wavelength. An array sensor is located at this focus point.

The amount of detected energy for each wavelength is then converted to a digital value by a 16-bit A/D converter, based on which the spectral radiant luminance and chromaticity are calculated by the processing section of the CS-1000A.

Sensor Section

The sensor section has a photo diode array consisting of 512 elements. The array is always kept at approximately 5 °C using a Peltier cooler, irrespective of the ambient temperature. This can reduce dark current and improve S/N ratio, thus enabling measurement of low luminance.

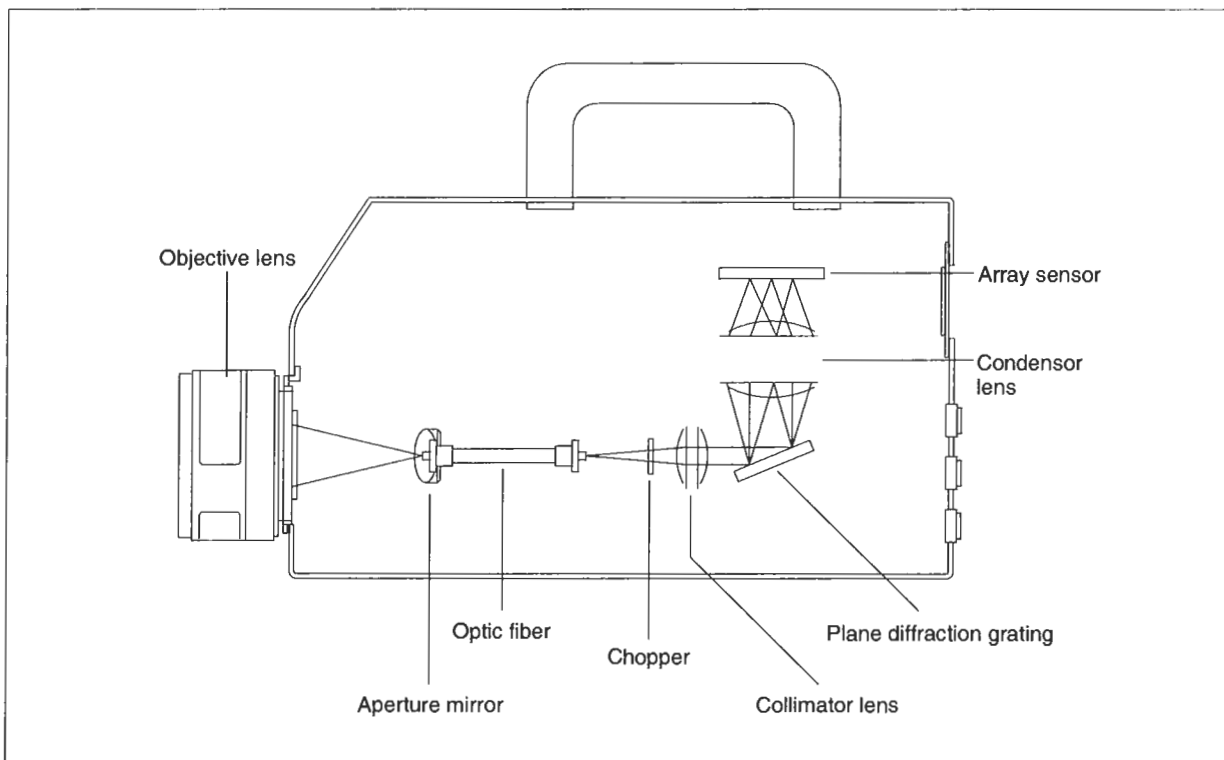

DARK MEASUREMENT

Each measurement consists of "light measurement" and "dark measurement".

"Light measurement" is performed with light from the object irradiating the sensor, while "dark measurement" is performed with no light from the object irradiating the sensor, so that detector dark current is measured.

When measurement starts, first "light measurement" is performed. When "light measurement" is complete, the shutter will close automatically, then "dark measurement" starts immediately.

"Dark measurement" is performed with the same integration time used for "light measurement". The final measured data is obtained by subtracting the measured data obtained in "dark measurement" from the one obtained in "light measurement". This method eliminates influences of dark current of the array sensor, resulting in improved measurement accuracy.

MEASURING COLOR OF THE OBJECT

Use of the CS-S10w software supplied with the CS-1000A enables simple measurement of the color of the object. For a detailed description of the operation, refer to the Software Instruction Manual. By selecting light source data stored in the software (CS-S10w) as the light source to be observed, the measured chromaticity can be evaluated against this light source.

- Place the white calibration plate and the object to be measured at the same angles in the same position. If the lighting and measuring conditions of the white calibration plate do not match those of the object, spectral data will fluctuate, resulting in incorrect measurement.
- The light source must be lit using constant-voltage power supply to ensure stable lighting during measurement.

Making Settings Necessary for Measurement of Object Color.

1. Have one or more light sources (e.g., tungsten-filament lamp), and set the white calibration plate in place as shown on the right.

- The white calibration plate must be positioned at right angles to the CS-1000A.
- Each light source must be positioned at 45 degrees to the CS-1000A.

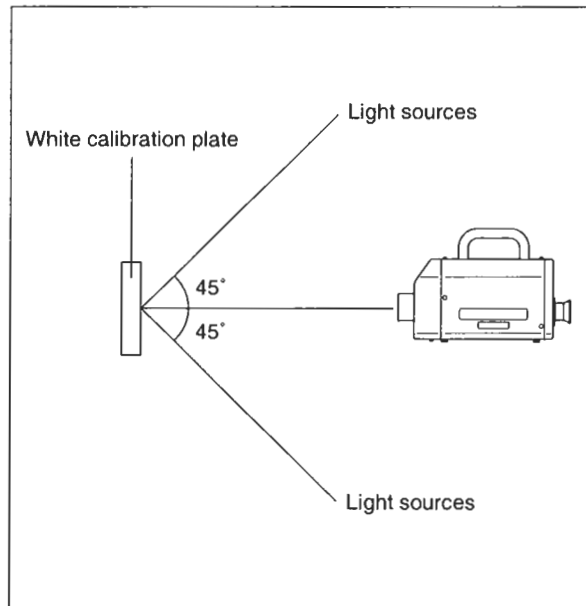

2. Start up the CS-1000A, personal computer and software (CS-S10w).

Performing White Calibration

3. Select AUTO measurement mode. (See pages 16 to 17.)
4. From the CS-S10w, select "Object Color" for the color to be measured.
5. From the CS-S10w, Perform white calibration.

- ◆ For details, refer to the CS-1000A Software Instruction Manual.

Measuring the Spectral Reflectance of the Object

6. Place the object at the same angles in the same position as the white calibration plate.
7. From the CS-S10w, start measurement.

- ◆ For details, refer to the CS-1000A Software Instruction Manual.

ERROR MESSAGES

Error Message	Cause	Action
OVER	The measured spectral value was beyond the sensor's saturation exposure level.	For MAN measurement mode, decrease the integration time so that no OVER error appears. If the integration time is already set to 40 ms or this error occurs in AUTO measurement mode, decrease the luminance of the object by placing a mesh filter in front of the objective lens.
	For MAN measurement mode, a value 1.3 times the integration time set in AUTO measurement mode or higher was set for a light source whose luminance was within the measuring range.	
	It was not possible to set an appropriate integration time for AUTO measurement mode due to extreme fluctuation of the object's luminance.	Stabilize luminance of the object, or switch to MAN mode and set longer integration time within the range in which no OVER error occurs. To measure a display, switch to INT.SYNC or EXT.SYNC mode.
UNDER	The peak value of measured spectral value was approximately 13 % of the sensor's correct exposure level or lower.	For MAN measurement mode, increase the integration time so that no UNDER error appears. If the integration time is already set to 60 sec. or this error occurs in AUTO measurement mode, increase the luminance of the object.
	It was not possible to set an appropriate integration time for AUTO measurement mode due to extreme fluctuation of the object's luminance.	Stabilize luminance of the object, or switch to MAN mode and set longer integration time within the range in which no UNDER error occurs. To measure a display, switch to INT.SYNC or EXT.SYNC mode.
LENS ERROR	No objective lens was attached.	Attach the objective lens supplied with the CS-1000A.
	An objective lens other than the one supplied with the CS-1000A was attached.	
SYNC ERROR	No external vertical sync. signal was input during EXT.SYNC measurement mode.	Input a vertical sync. signal having an appropriate frequency to the BNC terminal of the CS-1000A.
	The frequency of external vertical sync. signal was outside the allowable range (20 to 250 Hz).	
NO TARGET	Color difference mode was selected without target data.	Input the target data.
DATA SET ERROR	The integration time was set below 0.040 seconds or above 60.001 seconds for MAN measurement mode.	Input an appropriate value.
	The frequency was set below 20.00 Hz or above 250.01 Hz for INT.SYNC measurement mode.	
	An attempt was made to save the manually input value not conforming to the setting conditions (see page 36) as target data.	
MEMORY ERROR	Measured data and target data saved in the memory and target data which was entered manually were destroyed.	Create the data from the beginning. If this error occurs frequently, contact the nearest Konica Minolta authorized service facility.
ROM ERROR	The calibration data saved in the ROM was destroyed.	Set the POWER switch to OFF, then set it to ON again. If this error still occurs, contact the nearest Konica Minolta authorized service facility.
HARDWARE ERROR	Electric circuit was not operating properly.	
-----	The relative luminance is out of the display range in the case of color difference measurement. (Display range: $L_v\% \leq 999900\%$)	
	The relative color temperature for $T_{\Delta uv}$ or the color difference from the blackbody locus is out of the display range. (Display range: $2300K \leq T \leq 20000K$ or $\Delta uv < 0.1$)	

TROUBLESHOOTING

If the symptom remains even after the actions given in the table are taken, contact an authorized service facility. When making contact, you may be asked to give the version of the CS-1000A you are using, so please make sure that you check the version as explained below prior to making contact.

Version Check Method

1. Turn the power ON while holding the **MENU** and **SELECT/CANCEL** keys together.

- ◆ The version no. will appear on the LCD.

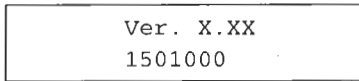

- Take a note of what is displayed.
 1st model: 1.30xx or earlier Measuring speed is fixed.
 2nd model: 1.30xx or later Measuring speed can be selected from NORMAL and FAST.

2. Press any key to exit.

- ◆ The measurement screen will reappear.

Symptom	Check Points
LCD does not light up even if the POWER switch is set to ON.	Is the AC adapter connected to an AC outlet?
	Is the AC adapter connected to the CS-1000A?
Nothing is observed when looking into the finder, since the field of vision is dark.	Has the protective cap been removed from the objective lens?
	Has the ND filter been removed from the finder?
"Remote on" message does not appear on the LCD or the CS-1000A cannot be controlled even if it is connected to a host computer via the RS-232C interface.	Is the RS-232C cable connected properly?
	Is the RS-232C cable of the cross type?
	Is the baud rate correct?
Measurement cannot be performed even if the MEAS/STOP key is pressed.	Measurement cannot be performed from the menu screen or memory screen, so it must be checked.
Measured values are inconsistent.	Has the CS-1000A been warmed up sufficiently? (If the power is turned off, the CS-1000A should be warmed up again for at least 15 minutes.)
	Is operation of the object stable?
	Does the ambient temperature fluctuate considerably?
	The integration time used for MAN measurement mode must not be far below the one set in AUTO measurement mode, so it must be checked.

DIMENSION DIAGRAM

(Units: mm)

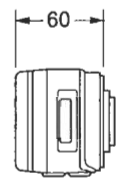

Macro lens

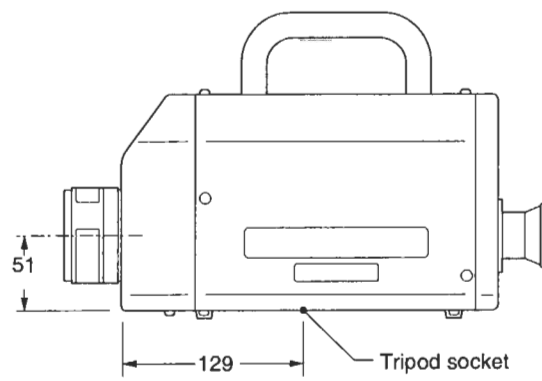
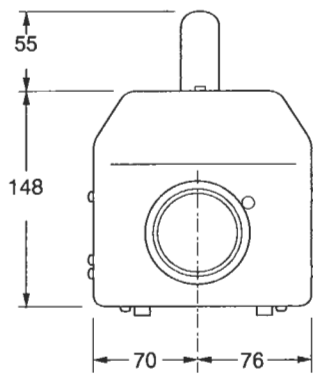
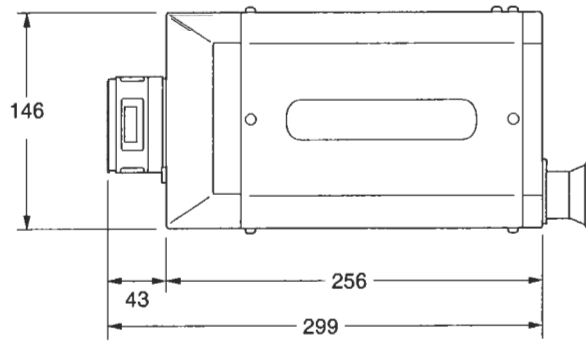

SPECIFICATIONS

Model Name	CS-1000A		
Wavelength Range	380 to 780 nm		
Wavelength Resolution	0.9 nm/pixel		
Spectral Bandwidth	5 nm (Half bandwidth)		
Spectral Method	Flat diffraction grating		
Photo Detector Element	512 linear image sensor elements (thermoelectrically cooled)		
Acceptance Angle	1 degree		
Minimum Measuring Area	7.9 mm (with standard lens)		
	1.15 mm (with macro lens)		
Minimum Measuring Distance	45 cm (with standard lens)		
	20 cm (with macro lens)		
Luminance Display Range	0.01 to 80,000 cd/m ² (standard light source A)		
Accuracy *1	Luminance: ±2% ±1 digit	Luminance range (standard light source A)	1 to 8,000 cd/m ² (with standard lens) 10 to 80,000 cd/m ² (with macro lens)
	Chromaticity: x: ±0.0015, y: ±0.001		
Repeatability σ	Luminance	Standard lens 0.1%+1digit (NORMAL, 1~8,000 cd/m ²), 0.1%+1digit (FAST, 1~8,000 cd/m ²) 0.1%+1digit (NORMAL, 0.5~1 cd/m ²), 0.1%+1digit (FAST, 0.5~1 cd/m ²) Macro lens 0.1%+1digit (NORMAL, 10~80,000 cd/m ²), 0.1%+1digit (FAST, 10~80,000 cd/m ²) 0.1%+1digit (NORMAL, 5~10 cd/m ²), 0.1%+1digit (FAST, 5~10 cd/m ²)	
	Chromaticity	Standard lens 0.0002 (NORMAL, 1~8,000 cd/m ²), 0.0004 (FAST, 1~8,000 cd/m ²) 0.0003 (NORMAL, 0.5~1 cd/m ²), 0.0006 (FAST, 0.5~1 cd/m ²) Macro lens 0.0002 (NORMAL, 10~80,000 cd/m ²), 0.0004 (FAST, 10~80,000 cd/m ²) 0.0003 (NORMAL, 5~10 cd/m ²), 0.0006 (FAST, 5~10 cd/m ²)	
Spectral Accuracy	±0.3 nm (mean wavelength: 546.1 nm Hg lamp)		
Polarization Error	Less than 5% (400 nm to 780 nm)		
Integration Time *2	NORMAL: 40 msec to 60 sec, FAST: 40 msec to 15 sec.		
Display	Le, Lvxy, Lvu'v', LvT Δ uv, Δ Lvxy, Δ Lvu'v' (Observer can be switched between 2° and 10°)		
Power	AC adapter AC-A12 (120V~, 60Hz or 230V~, 50Hz)		
Interface	RS-232C		
Operating temperature/humidity range	5 to 35°C; Relative humidity 80% or less (at 35°C) with no condensation		
Storage temperature/humidity range	0 to 45°C; Relative humidity 80% or less (at 35°C) with no condensation		
Size and Weight	146 × 148 × 256 mm, 4.7 kg (main body) φ65.5 × 43 mm/0.2 kg (standard lens); φ72 × 60 mm/0.3 kg (macro lens)		
Standard Accessories	Standard Lens, Macro Lens, RS-232C cable (D-sub9-pin), AC adapter AC-A12, ND Eyepiece filter CS-A1, Calibration Certificate, Data management software CS-S10w Professional		
Optional Accessories	Tripod CS-A3, Panhead CS-A4, White Calibration Plate CS-A5, ND Filter (10%) CS-A6, ND Filter (1%) CS-A7, Hard Case CS-A2		

Note 1) Measuring conditions: Measuring speed NORMAL (standard illuminant A)

Note 2) Measurement time is twice integral time plus α (α is 4 ~ 9 sec. and varies with the measuring luminance).

- The above specifications are subject to change without notice.



KONICA MINOLTA